



MURPHY®

EMS PRO LITE

COMPACT, FLEXIBLE INDUSTRIAL PUMP CONTROLLER

	Perfect for Dewatering and Irrigation Applications
	Pressure, Level and Float Start/ Stop Types
	Backlit Graphical Display and Alarm Indicating LEDs
	Tier 4 and Stage IIIB/IV ready
	Wide Operating Temperature Range
	Supports Mechanical and Electronic Engines



Looking for an industrial pump controller tailored for specialized applications?

EMS PRO LITE was designed with dewatering and irrigations applications in mind. The controller features a compact enclosure and focused feature set, including pressure, level and float start/stop types, for the ideal balance of functionality and control needed to perform specific application functions.

The user-friendly interface features eight touch buttons, and a backlit graphical display visible in all types of conditions. The interface is mounted directly to the front of the NEMA 4 enclosure for easy access and operation.

See the full specifications on the back of this sheet for a full overview of EMS PRO LITE technical features.

STANDARD DIMENSIONS

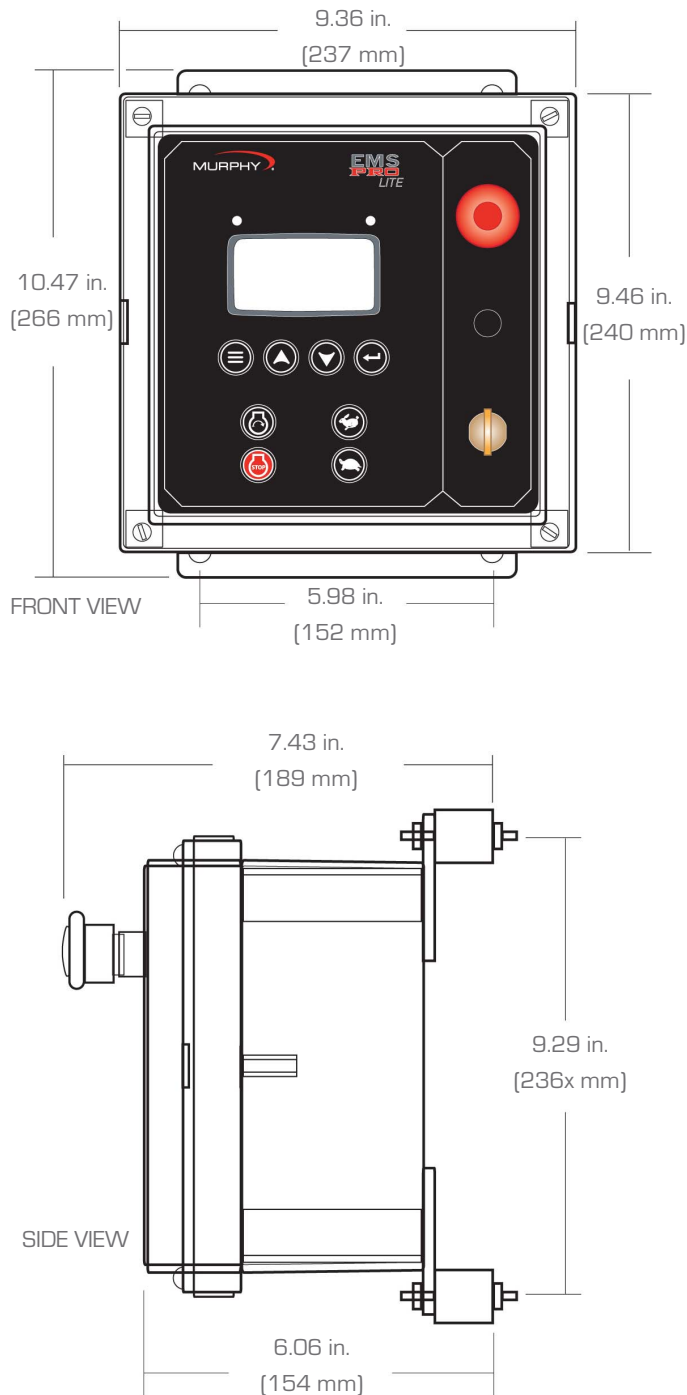

TECHNICAL SPECS:

- Operating Voltage: Engineered for 12VDC systems (8 VDC Minimum to 14.4 VDC Maximum)
- Operating Temperature and Storage Temperature: -40° to 80°C (-40° to 176°F)
- Standby Current: @ 12V, 140mA
- LEDs: 2 - Alarm (Amber); Shutdown (Red)
- CAN Bus: SAE J1939 Compliant
- Enclosure: Polycarbonate Nema 4 (UL Listed)
- Analog Inputs: 6 designated via program; sender/ground digital, 4 - 20 mA, 0 - 5VDC
- Digital Inputs: 4 high/low
- Frequency Input: 1 optically isolated input for speed reference, magnetic pick-up (30 - 10kHz)
- Fuel Sender Input: 33 Ohm full, 240 Ohm empty
- Analog Output: 1 dedicated for analog throttling (0.4 - 4.6VDC)
- Digital Outputs: 6 dedicated via program
- Relays: 2 SPDT Common NO wired, rated @ 8 Amps as installed
- User Interface: 8 button membrane switch
- Connectors: One 21 pin Deutsch HDP20 and One 9 pin Deutsch HD10 Series
- Environmental Sealing: IP65
- Mounting: 4 isolated 0.75 inch rubber shock mounts
- Shipping Weight: 7 Lb. (3.2 kg)
- Shipping Dimensions: 12 x 12 x 10 in. (304.8 x 304.8 x 254 mm)

FW MURPHY

P.O. Box 470248
Tulsa, Oklahoma 74147 USA +1 918 317 4100
Fax: +1 918 317 4266
E-mail: sales@fwmurphy.com

FW MURPHY (LATIN & SOUTH AMERICA)

E-mail: samericasales@fwmurphy.com

FW MURPHY (INDIA)

E-mail: indiasales@fwmurphy.com

FRANK W. MURPHY, LTD

Church Rd Laverstock, Salisbury SP1 1QZ UK
Phone: +44 1722 410055 Fax: +44 1722 410088
E-mail: sales@fwmurphy.co.uk
Web site: www.fwmurphy.co.uk

FW MURPHY INSTRUMENTS (HANGZHOU) CO. LTD

77 23rd Street
Hangzhou Economic & Technological Development Area
Hangzhou, Zhejiang 310018 China
Phone: +86 571 8788 6060 Fax: +86 571 8684 8878
E-mail: apsales@fwmurphy.com



USA-ISO 9001:2008 FM 28221
UK-ISO 9001:2008 FM 29422
CHINA-ISO 9001:2008 FM 52385
Registered Facilities

COMPUTRONIC CONTROLS, LTD

41 - 43 Railway Terrace Nechells
Birmingham B7 5NG UK
www.computroniccontrols.com



MURPHY
www.fwmurphy.com