

# Installation Instructions for LR857 Level Regulator



Please read the following information before installing. A visual inspection of this product for damage during shipping is recommended before mounting. **CRANKCASE MUST BE DRAINED BEFORE INSTALLATION.**

## GENERAL INFORMATION

### WARNING

BEFORE BEGINNING INSTALLATION OF THIS MURPHY PRODUCT

- ✓ Disconnect all electrical power to the machine.
- ✓ Make sure the machine cannot operate during installation.
- ✓ Follow all safety warnings of the machine manufacturer.
- ✓ Read and follow all installation instructions.



### Description

Murphy LR857 Lube Level Regulator maintains the crankcase oil level of an engine, pump or compressor. Adjusted to the correct *running-oil-level*, the LR857 will replenish oil as it is used. An integral, low-level switch will alarm and/or shutdown the equipment if supply oil is lost and the equipment continues to use oil.

### Specifications

**Inlet Connection:** 5/8 in. (16 mm) I.D. hose

**Outlet Connection:** 3/8 NPT

**Snap-switch:** SPDT rating 10 A @ 125 VAC; 0.5 A @ 125 VDC; 10 A @ 30 VDC

**Conduit Connection:** 1/2 NPT

**Case:** Die cast aluminum

**Lens:** Polycarbonate

**Float:** Brass

### Optional Mounting Brackets And Fittings Kit

Murphy offers two mounting brackets for the LR857. The (15000238) Pipe Bracket Kit fits a 7/8 in. (22 mm) diameter pipe. The (15010224) Universal Flange Kit allows various mounting methods. See Dimensions section on reverse side.

The (15000420) Fittings Kit includes the following:

Quantity	Description
1	1/4 in. (6 mm) O.D. copper cane tube (vent connection)
1	1/4 in. (6 mm) tube x 1/4 male pipe fitting
1	1/2 in. (13 mm) I.D. hose fitting (outlet connection)

### Flow Rates Oil with 0.9 specific gravity @ 70°F (21°C)

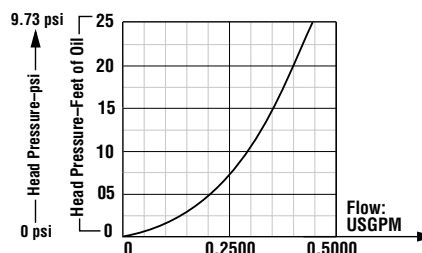

### Thumb-Valve™ Operation

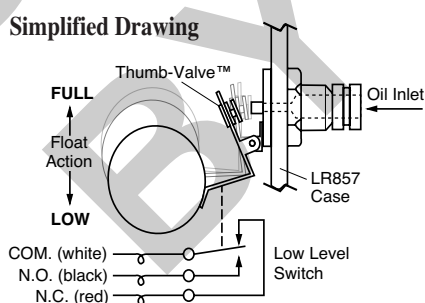

As the equipment uses oil, the float falls, providing immediate level compensation. At FULL position, the float holds the valve closed. If the clean oil supply is depleted and oil level continues to fall, the low level switch will operate an alarm or equipment shutdown.

### Service Parts

Part Number	Description
15000159	Inlet Valve Assembly
15000100	Glass and Switch Assembly
15000161	Lid Assembly
15000941	Float Assembly (Brass-std)
15010224	Universal Flange Kit
15000238	Pipe Bracket Kit
15000420	Fittings Kit

\* Products covered by this literature comply with EMC Council directive 89/336/EEC regarding electromagnetic compatibility except as noted.

## DIMENSIONS

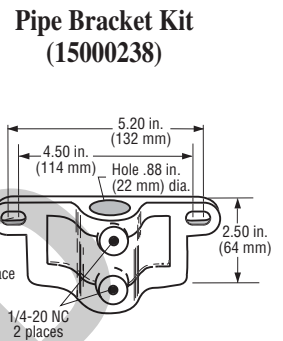
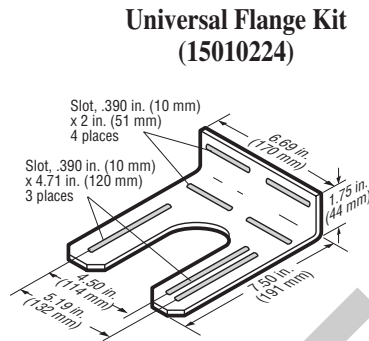
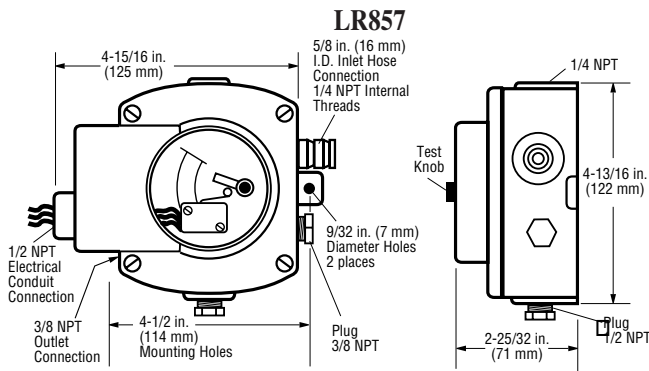

## TYPICAL INSTALLATION

**Connection of the LR857 must be made to the equipment crankcase at the lowest possible point—usually the oil drain plug. Hoses, hose clamps and supply tank are supplied by the customer. Also these instructions are based on the Murphy optional fittings kit described on the reverse side. If you did not order the fittings kit, gather the proper fittings as specified on the reverse side.**

1. Determine the mounting location on or near the equipment for the LR857. Mount the LR857 using the optional pipe mounting bracket (15000238) or universal mounting bracket (15010224) or suitable customer supplied mounting. **NOTE:** Mounting must allow vertical adjustment of the LR857 to locate proper regulated level.
2. Drain the crankcase and attach a 1/2 in. (13 mm) I.D. flexible hose from the crankcase to the oil outlet port on the LR857. **CAUTION:** The hose must slope slightly downward from the LR857 and **MUST NOT** have any droop or low spots. **NOTE:** If the drain plug on the crankcase is used for the connection, we recommend installation of a tee to allow draining of the crankcase for service. All hoses should be as short in length as possible.

3. For sealed crankcases, connect a 1/4 in. (6 mm) O.D. tube from the crankcase to the tube fitting on the LR857 (see drawing below). For vented crankcases install the copper cane. **CAUTION:** The crankcase vent connection **MUST BE** above the oil level so that the tubing will not be restricted by oil splash, etc. Failure to install the tubing or cane vent will result in improper operation and oil spillage.

**BEFORE CONTINUING, VERIFY THAT ALL HOSE CLAMPS ARE TIGHT**

4. Refill the crankcase to the proper oil levels. Vertically adjust the LR857 so that the pointer is consistent with the actual running oil level in the crankcase. Check this level against the “add oil” marking on the dip stick. To determine the level at which you wish oil to be added, either drain oil from the crankcase or slightly lower the LR857 mounting so that the pointer/switch actuator will indicate the level at which oil will be added. This can be estimated by lowering the LR857 an amount equal to the difference between the “FULL” and “ADD” marks on the dip stick. Tighten the mounting bracket.
5. Connect a hose between the oil inlet of the LR857 and the oil supply tank. The hose must maintain a downward slope and not have low spots or droops. A minimum height of 2 ft. (0.6m) above the LR857 is recommended. Maximum head is 25 ft. (7.7 meters) or 10 psi (6.9 kPa) [0.69 bar]. **NOTE:** We recommend a shutoff valve be attached in the bottom of the supply tank. A filter screen between the supply and the LR857 is also recommended.
6. Before filling the supply tank with oil, be sure the tank is clean and dry and the shutoff valve is closed. Also, be sure all hoses and clamps are tight. Fill the tank with clean oil.
7. After oil supply tank is full, open the shutoff valve.

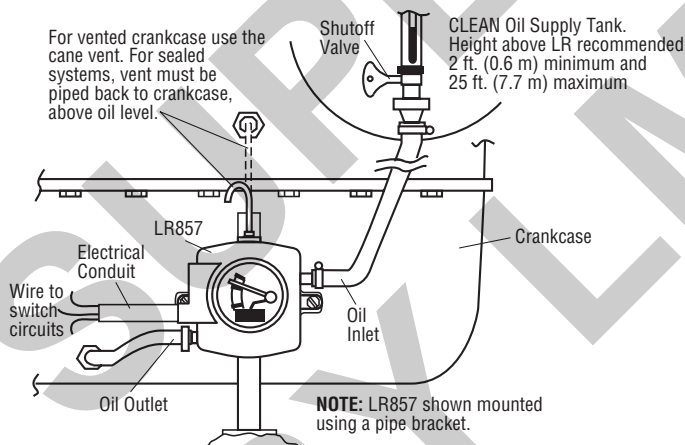

**WARNING: Overfill condition can be caused by excessive inlet pressure and/or improper “vent to crankcase” installation.**

8. Make the proper electrical connections for the application. See contact ratings on reverse side.

# MURPHY

### FW Murphy

P.O. Box 470248  
Tulsa, Oklahoma 74147 USA  
+1 918 317 4100 fax +1 918 317 4266  
**e-mail** sales@fwmurphy.com

**www.fwmurphy.com**

### CONTROL SYSTEMS & SERVICES DIVISION

P.O. Box 1819; Rosenberg, Texas 77471; USA  
+1 281 633 4500 fax +1 281 633 4588  
**e-mail** sales@fwmurphy.com

### MURPHY DE MEXICO, S.A. DE C.V.

Bld. Antonio Rocha Cordero 300, Fracción del Aguaje  
San Luis Potosí, S.L.P.; México 78384  
+52 444 8206264 fax +52 444 8206336  
Villahermosa Office +52 993 3162117  
**e-mail** ventas@murphymex.com.mx  
**www.murphymex.com.mx**

### FRANK W. MURPHY, LTD.

Church Rd.; Laverstock, Salisbury SP1 1QZ; U.K.  
+44 1722 410055 fax +44 1722 410088  
**e-mail** sales@fwmurphy.co.uk  
**www.fwmurphy.co.uk**



**ISO 9001**  
REGISTERED

USA-ISO 9001:2000 FM 28221  
UK-ISO 9001:2000 FM 28422

Printed in U.S.A. 1190077