

EMS447 and EMS448 Models

Operation Instructions Section "2"

Standard Program #01 (A94035) V12 and Later

EMS-94132N
Revised 6-03
Section 40
(00-02-0201)





Caution: Certain danger to human safety and to equipment such as applied in mobile or marine application may occur if some equipment is stopped without prewarning. In those cases it is recommended that monitored functions be limited to alarm-only or to alarm before shutdown.

EMS

Modes of Operation

The EMS447 and EMS448 monitor your engine/motor conditions and count down the service reminders. When a shutdown occurs, the fuel valve will turn off and the display will show the cause of shutdown. TOA switch must be moved to "OFF" to reset.

The EMS447 and EMS448 have two standard modes of operation which can be configured in the S-Numbers, these modes of operation are described as follows:

Manual Mode: When this mode is selected, the EMS performs as a monitoring engine panel. It will alarm when faults are detected and initiate shutdowns based on shutdown switches and gage senders. It will also remind you when service is required for your equipment.

Automatic Mode: In the Automatic Mode, two of the shutdown inputs available in the Manual Mode are redefined. Instead of shutdowns for V-belt Break and Low Oil Level, automatic throttling inputs are available. All S-numbers are used and must be configured in the Automatic mode.

Sequence of Operations

Automatic Mode of Operation

(TOA switch is in Auto, see Scrolling Main Displays, 8. Selector, p-2.)

I. A Start Signal is received

- a.** The start delay begins timing. If the start signal is sustained throughout this delay, step **b.** is executed. If the start signal is not sustained throughout this delay, nothing happens.
- b.** The prelude/glowplug output turns on throughout the prelude/glowplug delay.
- c.** The Fuel and Crank outputs turn on. The crank output turns on for the adjustable crank time. It then turns off for the adjustable rest time. If the engine starts, step **d.** is executed. If the engine does not start in the adjustable number of cranking attempts, the unit will display OVERCRANK, turn off the fuel and crank outputs, and turn on the common fail output. If the engine false starts, the unit will wait through the adjustable recrank delay before attempting another engine crank.
- d.** When the unit senses an engine RPM higher than the crank stop RPM, the crank and glowplug outputs turn off and the following begin timing:
 1. Internal hourmeter.
 2. Lockout Delay. Low Oil Pressure and High Engine Temperature shutdowns are locked out during this delay.
 3. Warm-up Delay.
- *e.** The unit signals the engine to throttle up to the warm-up RPM.
- *f.** Once the warm-up delay expires, the EMS signals the engine to throttle up to Minimum RPM and the clutch output turns on. If the engine throttling inputs call for an engine increase or decrease, the unit will signal the engine to respond accordingly.

NOTE: The EMS will always try to throttle the engine between the minimum and maximum RPM set-points when at the AT-LOAD state.

II. A Stop Signal is received

- a.** The stop delay begins timing. If the stop signal is sustained through the stop delay, step **b.** is executed. If the stop signal is not sustained through

the stop delay, the unit will continue to run.

- b.** The Cooldown delay begins timing.
- *c.** The unit signals the engine to throttle down to an idle.
- *d.** When engine speed reaches the clutch release RPM, the clutch output turns off.
- e.** When the cooldown delay expires, the following items occur:
 1. Fuel valve turns off.
 2. Internal hourmeter stops timing.
- f.** The unit is ready for another start signal. If the TOA switch is moved to the TEST position, delay on start and stop will be ignored. The unit will start normally and run through the sequence. When TOA switch is moved to OFF, the unit will signal the engine to shut down without a cooldown period.

Manual Mode of Operation

In the manual mode, the unit gets its power from the ignition position of the engine start key switch. The following sequence occurs when the unit first powers up.

I. Power is Supplied to the EMS

- a.** Fuel valve output turns on.
- b.** The "Failed To Start" Delay will begin timing (fixed to 5 minutes).
If the engine is not started within 5 minutes, "Failed To Start" is displayed and the fuel valve is turned off.
- c.** When the engine speed is sensed to meet or exceed the Crank Stop set-point, the following delays will begin timing.
 1. Internal hourmeter.
 2. Lockout Delay. Oil pressure and engine temperature shutdowns are locked out during this delay. The unit must sense an engine RPM higher than the crank stop RPM before this delay expires or it will turn off the fuel valve and show No Speed Signal.

II. Key Switch is turned Off (power removed from EMS)

- a.** Fuel valve output turns off.

Operating the Interface

By using the three membrane buttons and the liquid crystal display, you can make

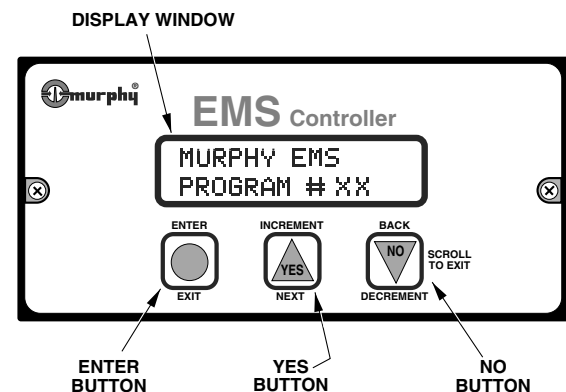

set-point changes, acknowledge alarms, and scroll through the display. The graphic below shows the display and buttons.

- The **ENTER (EXIT)** button is used to confirm a set-point, get into and out of a display and to acknowledge alarms.
- ▲ The **YES (INCREMENT)** button is used to scroll up the display, to select messages, and enter value increments.

* When equipped with Murphy AT-67207 or other throttling device.

** When equipped with Murphy CO3 or other clutch operator device.

- ▼ The **NO (DECREMENT)** button is used to scroll down the display, to select messages, and enter value decrement.

Scrolling Main Displays

During normal operation, the EMS allows you to scroll through a number of informative displays. You can manually scroll through monitored information by pressing ▲ or ▼ buttons, or you may set the unit for automatic scrolling.

While scrolling, the EMS remains fully operational. When a shutdown occurs or a service reminder comes due, the unit will display the corresponding information regardless of the scrolling mode. When first powered up, the EMS will delay for one minute before starting to scroll. When the scrolling mode is changed a 10 second delay must time out before scrolling resumes.

To set the Automatic scroll, press the ● and ▲ buttons simultaneously. To set the Automatic scroll mode to off, press ● and ▼ buttons at the same time. The Automatic scroll off enables you to Manually scroll the unit. See displays listing and explanation below:

1. MURPHY EMS

This is the first line of the title page.

2. PROGRAM #01

This is the second line of the title page. It shows which program is installed in your unit. This information is helpful when calling for technical assistance.

3. RUN HOURS XXXX.X

This is your on board hour meter. It digitally displays the number of hours your engine has been running. All the service reminders are based on the elapsed time on the hourmeter.

4. BATTERY XX.X VDC

This displays your system voltage.

5. ENG SPD XXXX RPM

This displays the current engine RPM. Decisions to stop cranking and shutdown on overspeed / underspeed are based on this number. Remember to calibrate this in the S-numbers.

6. OIL PR XXX PSI

This displays the current engine oil pressure as sensed from an electric gauge sender, or pressure transmitter. Shutdowns based on oil pressure reference this number.

7. ENG TEMP XXX °F

This displays the current engine temperature as sensed from an electric gauge sender. The unit will signal the engine to shutdown if this temperature reading exceeds the shutdown point selected in S10.

8. SELECTOR - XXXX

(Replaced with MANUAL MODE when unit is used as a manual panel)

There are three positions on the selector switch that are displayed on this line: TEST, OFF and AUTO or (TOA). When this window shows AUTO, your TOA switch is in the AUTO position. When in AUTO, the unit is ready to start the engine or already has started it. When this window shows OFF, your TOA switch is in the OFF position. The unit will not initiate an auto start with the switch in the OFF position. If the switch is moved to the OFF position while the engine is running, the unit will signal the engine to stop. When this window shows TEST, your TOA switch is in the TEST position. When the switch is flipped to TEST, the unit will start the engine as if a start signal had been received; regardless of the start/stop contacts.

9. ST: XXXXXXXXXXXX

ST stands for STATE. This window shows what state your controller is in. States include the following: NOT READY, PANEL READY, START DLY, PRELUBE, CRANK ON, CRANK OFF, WARMUP, AT LOAD, SHUTDOWN, STOP DLY and COOLDOWN.

NOT READY: This state occurs when the selector is in the OFF position. It means that the panel is not ready to run in Automatic mode.

PANEL READY: This state occurs when the selector is in the AUTO position and no shutdowns have occurred. It means that the panel is ready to run in Automatic mode.

START DLY: This state occurs when a start signal is sensed and the start delay is timing. The start signal must be present throughout this delay before the

unit goes to the next state.

PRELUBE: This state occurs after the Start Delay expires. During the Prelube state, the prelube output is turned on.

CRANK ON: This state occurs after Prelube Delay expires. During Crank On state, the unit energizes the starter circuit and attempts to start the engine.

CRANK OFF: This state occurs after the Crank On state if the unit senses that the engine has not started. During the Crank Off state, the unit removes power from the starter circuit to cool off the starter before another cranking attempt is made.

WARMUP: This state occurs after the unit senses that the engine has started. During this state, the unit throttles the engine* to the warmup RPM and stays at this engine speed until the Warmup Delay expires. The Lockout Delay also begins timing when the Warmup State begins.

AT LOAD: This state occurs after the Warmup state concludes. It can also occur if a start signal is received during the Cooldown state (see Cooldown below). When the At Load state first begins, the clutch circuit is activated and the unit brings the engine* speed to Minimum RPM or higher, depending on system demand.

STOP DLY: This state occurs when a stop signal is sensed and the stop delay is timing. The stop signal must be present throughout this delay before the unit goes to the next state.

COOLDOWN: This state occurs after the Stop Delay has expired. During the Cooldown state, the unit throttles the engine* to an idle. As the engine RPM passes through the Clutch Release RPM, the unit will deactivate the clutch circuit. If a start signal is received during the Cooldown state, the unit will switch to the At Load state and ignore the Warm-up state.

SHUTDOWN: This state occurs if a shutdown condition is detected. Reasons for shutdown include low oil pressure, high engine temperature, overspeed, etc. During this state, the engine is signalled to shutdown and all start signals are ignored until the unit is reset by moving the selector to the OFF position and then back into AUTO or TEST.

10. CHG OIL XXX HRS

This display shows the number of running hours remaining before the oil must be changed in the engine.

11. OIL FLT XXX HRS

This display shows the number of running hours remaining before the oil filter on the engine must be changed.

12. FUEL FLT XXX HRS

This display shows the number of running hours remaining before the fuel filter on the engine must be changed.

13. AIR CLNR XXX HRS

This display shows the number of running hours remaining before the air cleaner on the engine must be serviced or changed.

14. SERV BAT XXXX HRS

This display shows the number of running hours remaining before the engine cranking battery must be serviced or changed.

Service Reminders

The EMS has the above built in service reminders. When a service reminder comes due, the EMS will stop scrolling and display the service reminder message. If you cannot perform the service at that moment, you may press the ● (ENTER) button and the message will go away for 4 hours and normal scrolling will resume within 10 seconds approximately.

Once you perform the service, enter the P-Numbers and select the service that is due. Toggle the (NO) to a (YES) and the count down Timer will reset to the number of hours programmed in the S-Numbers.

Loss of Sender Feature

If the EMS senses that a sender wire has broken or the value from the sender is out of known bounds, the EMS will display a "Loss of Sender" alarm message and initiate a shutdown. There are alarms for loss of temperature sender, oil pressure sender and the magnetic pick-up speed sensor.

If you get a lost sender message for temperature or pressure, check the

* When equipped with Murphy AT-67207 or other throttling device.

connections between the controller and the sender. Also check that the sender has a good ground. If the alarm is for the magnetic pick-up, confirm you are getting at least 2 Vrms from the magnetic pick-up.

How to access the S-numbers

Also refer to the "Quick-reference" sheet supplied with these instructions.

1. Press the ▼ button until the title page appears.
2. Press the ● button until the entry code screen appears.
3. Press the ▲ or ▼ buttons until the corresponding entry code is displayed.
4. Press the ● button once, the S-numbers main menu will be displayed.
5. Now that you are in the S-numbers, you can go to a specific function by pressing the ▲ or ▼ buttons then pressing the ● button to enter the specific function. Now you can increase, toggle, or decrease the setpoint.

All Setpoints use the above described procedure. You can exit the set-up mode by depressing and holding the ▼ button until the exit screen is displayed.



CAUTION: THE S-NUMBERS CONTAIN CRITICAL OPERATING PARAMETERS. ITEMS SET IMPROPERLY CAN CAUSE SERIOUS DAMAGE TO THE ENGINE.

Now press the ● button to set the EMS back into the Main Displays. If you forget to exit the S-numbers menu, the EMS will exit for you after 10 minutes.

S-Numbers Description and Listings

The S-numbers are used for customizing the controller to your specific engine. Included in the S-numbers are variables such as crank / rest times and warm-up / cool-down times. These S-Numbers must be set before trying to use the unit to auto start your engine. Following is a list of available S-Numbers and a short description of the function of each. The Factory Default values are shown in **bold** parentheses; the Adjust Range values are shown in standard parentheses.

S0 CIRCLE = EXIT

Used to exit the S-number setup mode.

S1 LINE SELECT

Used to change what is displayed on the top line throughout your S-number editing session. Your choices include: Engine Speed, Run Hours, Oil Pressure, Engine Temperature, and Input / Output status. The input and output status information will show an X if that particular input is active or output is ON. If there is no input or the output is OFF, the unit will display an O. This can be used for testing wiring before starting the engine. For more information, see the section titled "Double Checking Your Wiring".

S2 SPEED CALIB (120.00 PULS)

This setting (1.00 to 320.00), is used to calibrate the speed signal so that the unit will display engine RPM. This setting must be adjusted for items such as crank stop RPM and OVERSPEED RPM to work. Simply enter the number of Pulses per revolution the magnetic pickup or alternator supplies to the EMS. Another way to set this variable is to get the engine running at a known RPM and then change the number until the top line matches your known RPM. The resulting number is the pulses per revolution.

S3 OVERSPEED (2000 RPM)

This setting allows you to enter the highest speed the engine can run before damage is caused (0 to 10,000). If the unit senses that the engine has exceeded this speed, it will signal the engine to shutdown.

S4 UNDERSPEED (0 RPM)

If the engine speed dips to the RPM in this set-point, an automatic shutdown will be initiated (0 to 5,000). If you do not want to use this feature, change this variable to 0.

S5 LOCKOUT DELAY (30 SEC)

This delay (2 to 60), is used to ignore conditions such as low oil pressure when the engine first starts to allow the pressure time to reach its normal operating range.

S6 LOP @ LOW SPD (15 PSI)

The EMS gives you two oil pressure shutdown points (0 to 1000). For engines that develop very little oil pressure at an idle, you put a lower

shutdown setting in this set-point. The unit automatically changes the shutdown point between the Low Speed Shutdown point and the High Speed Shutdown point.

S7 LOP @ HI SPD (30 PSI)

This set-point (0 to 1000), is the higher oil pressure shutdown point that is referred to in S-number 6. This is the point that you want the engine to shutdown during normal high speed engine operation. By shutting down the engine at a higher oil pressure, you can avert damage that could be caused by waiting to shut down the engine at the lower set-point needed to accommodate an idle.

S8 LOP LO SPEED (600 RPM)

Set this to your engine idle speed (0 to 10,000). If the engine is running at this speed, an idle for example, and the oil pressure reaches the set-point selected in S6, the unit will initiate an automatic shutdown.

S9 LOP HI SPEED (1600 RPM)

Set this to your engine maximum speed (0 to 10,000). If the engine is running at this speed, and the oil pressure reaches the set-point selected in S7, the unit will initiate an automatic shutdown. The Graph below shows how the set-point changes between your high speed set-point and low speed set-point. As the engine speed increases, the unit automatically raises the oil pressure shutdown set-point along a straight line between the two

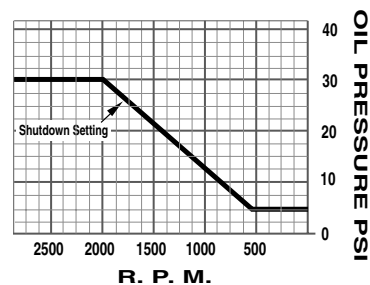

set-points you entered. This graph represents the following set-points: S6 is set to 5, S7 is set to 30, S8 is set to 600, and S9 is set to 2000.

NOTE: Once the speed reaches the high speed set-point, the oil pressure shutdown point will not increase any higher.

S10 HI ENG TEMP (220 °F)

Adjust this setting (0 to 400), to the engine temperature you do not want to exceed. If the unit senses an engine temperature higher than this set-point, it will initiate an automatic shutdown.

S11 PRESS UNITS (PSI)

Select the units of pressure you would like displayed on the digital read out. Your choices are: PSI (Pounds Per Square Inch); KPA (Kilo Pascals); BARS (Bar); KG□CM (Kilograms Per Square Centimeter).

NOTE: Also included are choices for selecting a bar graph of the units specified above.

S12 TEMP UNITS (°F)

Select the units of temperature you would like displayed on the digital read out. Your choices are: °F (Fahrenheit); °C (Celsius)

NOTE: Also included are choices for selecting a bar graph of the units specified above.

S13 CRK STOP (300 RPM)

This RPM set-point is used to adjust where the unit releases the starter during cranking (0 to 9999). Set this to the RPM the engine attains just as it starts. This way, the starter is not engaged unnecessarily after the engine starts. You must also set this set-point to the speed you release the starter while cranking. This is how the unit senses whether the engine is running or not. You will get a NO SPEED SIGNAL shutdown if this is adjusted to high.

S14 SPARE 1 TYPE (DLY ALM & SHTDWN)

S14 selects how the spare 1 terminal will handle an input signal. Your choices are: Immediate alarm only, Immediate alarm & Shutdown, Immediate alarm before shutdown, Delay alarm only, Delay alarm & shutdown, and Delay alarm before shutdown. An immediate type alarm, shutdown or both will be processed whenever the input is active. A delay type alarm, shutdown or both will be processed after the Lockout Delay has

expired (S5). The alarm before shutdown is fixed at 30 seconds. The next option is RPM LIMIT ENABLE, when selected, an input to spare 1 terminal (spare 1 input) will signal the unit to throttle the engine* to the setting in S34. When this input is not grounded, the unit will throttle the engine to the setting in S33. The engine must be in AT LOAD state for this throttle type to take effect. (This type will not function in Manual Mode.) Your final option is LOW OIL LEVEL. When this is selected, the unit will display LOW OIL LEVEL on the screen and shut the engine down if an input is sensed on the SPARE 1 terminal. This is an Immediate alarm and shutdown type.

S15 OIL PRESSURE TYPE

Enter in the type of oil pressure sensing device being used. Your choices include: SENDER: The program would accommodate the Murphy ES2P electric sender. XDUCER: The program would accommodate the Murphy PXMS pressure transducer. DIGITAL: The program would accommodate the Murphy 20P pressure Switchgag. Factory set to SENDER.

NOTE: LK2 #2 must be in the sender position for the "sender" or "digital" choices. It must be in the 4-20 position for the "xducer" choice.

S16 OIL PRESSURE SLOPE

With battery power applied and no pressure applied, enter the value displayed in the top line on the bottom line. This should be 51 if the transducer is producing exactly 4 ma. at zero pressure. This S# is not available if either SENDER or DIGITAL is selected in S15. Factory set to 51.

S17 OIL PRESSURE MAX

Enter in the maximum range of the PXMS oil pressure transducer. Example: PXMS-100 enter 100 in this set point. This S# is not available if either SENDER or DIGITAL is selected in S15. Factory set to 100.

S18 CHANGE OIL

Set the interval in engine running hours you wish to be prompted to change your engine oil. Factory set to 500.

S19 CHG OIL FLTR

Set the interval in engine running hours you wish to be prompted to change your engine oil filter. Factory set to 500.

S20 CHG FUEL FLT

Set the interval in engine running hours you wish to be prompted to change your engine fuel filter. Factory set to 1000.

S21 SERV AIR CLN

Set the interval in engine running hours you wish to be prompted to service your engine air cleaner. Factory set to 10.

S22 SERV BATTERY

Set the interval in engine running hours you wish to be prompted to service your cranking battery. Factory set to 120.

NOTE: After service reminder time values have been set, the new values will not take effect (become active) until they have also been acknowledged in P-Numbers P-15 through P-19.

S23 PANEL MODE

You have two options: MANUAL or AUTOMATIC. When Manual is selected, the unit will function as a standard engine monitoring panel. You must manually start the engine and throttle it to the desired speed. It will initiate shutdowns when faults are detected. Set-points relating to the Automatic mode will no longer display when this mode is selected. When AUTOMATIC is selected, the unit will perform all engine control automatically. Factory set to MANUAL.

S24 WARMUP DLY

You can adjust this variable to the number of seconds you want your engine to warm-up before it engages the clutch

and throttles up to an at load condition, or goes to the "at load" state (adjustable from 1 to 300 seconds). Factory set to 30.

S25 COOLDOWN DLY

You can adjust this variable to the number of seconds you wish to cool down your engine before it shuts off after a stop signal is received (adjustable from 1 to 300 seconds). Factory set to 60.

S26 PRELUBE DLY

If you have the requirement for prelube or possibly a glowplug, you can use this delay. Set in the number of seconds you wish the unit to turn on this output before it initiates a crank. Factory set to 1.

S27 ENG STRT DLY

Set this delay on engine start to the number of seconds that the start signal must be present before the unit accepts it and initiates an auto start sequence (adjustable from 1 to 300 seconds). Factory set to 1.

S28 ENG STOP DLY

Set this delay on engine stop to the number of seconds that the stop signal must be present before the unit accepts it and initiates a stop sequence (adjustable from 1 to 300 seconds). Factory set to 1.

S29 CRANK TIME

Set this delay to the desired amount of time you want each engine cranking attempt to last. Consult your engine manual for recommended cranking and resting times (adjustable from 1 to 300 seconds). Factory set to 10.

S30 REST TIME

Set this delay to the desired amount of time you want each rest period between cranking attempts to last. Consult your engine manual for recommended resting and cranking times (adjustable from 1 to 300 seconds). Factory set to 10.

S31 RECRANK DLY

This delay is used to adjust the amount of time the unit will wait for the engine to stop moving before attempting another crank if a false start occurs. A false start is when the engine starts but then dies before the LOCKOUT DELAY has expired (adjustable from 1 to 300 seconds). Factory set to 10.

S32 CRK ATTEMPTS

Set the number of attempts you would like the controller to try an engine start. If the engine fails to start after the number of attempts you have selected, it will fail the engine and display OVERCRANK on the front display. This shutdown requires a manual reset. Factory set to 6.

S33 MIN ENG RPM

Minimum engine RPM is the speed at which your engine must run for it's driven equipment to start performing work. For example, in a pumping application, minimum engine RPM is the speed at which an engine must run for fluid to begin being pumped. Set this variable to that speed. Factory set to 900

S34 MAX ENG RPM

Maximum engine RPM is the speed at which engine driven pump performance peaks. If the engine exceeds this speed, pump performance starts to deteriorate. This would be at the peak of a pump curve, for example. Set this set-point to that peak speed. For auto throttling at load, the controller will vary your engine speed between minimum and maximum RPM. Factory set to 1600.

S35 WARMUP RPM

** When equipped with Murphy AT-67207 or other throttling device.*

You can set a specific speed you would like the engine to run during the warm-up time delay in this set-point. Consult your engine manual for the optimum warm-up speed. Factory set to 700.

S36 RATE INC RPM

This set-point is used to customize how fast or slow you wish the unit to increase the engine speed during throttling. Experiment with this number until the desired throttling is achieved. Factory default for this set-point is 10 RPM per second. Factory set to 10.

S37 RATE DEC RPM

This set-point is used to customize how fast or slow you wish the unit to decrease the engine speed during throttling. Experiment with this number until the desired throttling is achieved. Factory default for this set-point is 10 RPM per second. Factory set to 10.

S38 CLUT REL RPM

During cooldown, the unit brings the engine to an idle. While it is throttling down, it passes through the clutch release RPM and drops out the clutch. Set this point to the RPM you would like the unit to automatically release the clutch during Cooldown. Factory set to 800.

S39 STRT/STOP TYPE

This set-point allows you to configure the type of automatic start / stop inputs you will use. If this set-point is adjusted to OPL, a momentary input to terminal 1(447), (31 on 448), (analog input 4 as a switch input) will cause a start and a momentary input to terminal 15(447), (34 on 448) (analog input 5 as a switch input) will cause a stop. The momentary input must be maintained for the length of the start or stop delay. If this set-point is adjusted to 1 MAINTAIN CNTCT, a start input must be present the entire time a run condition is required on terminal 1(447), (31 on 448), (analog input 4 as a switch input). When this input is taken away, the unit interprets this as a stop signal. If this set-point is adjusted to 2 MAINTAIN CNTCT, a start input must be present on both 1(447), (31 on 448), (analog input 4 as a switch input) and 15(447), (34 on 448), (analog input 5 as a switch input) before the unit will acknowledge a start. A stop is initiated after both inputs are removed. Factory set to OPL START/STOP.

S40 THR MIN PULS

This set-point is used to further customize the way the unit throttles your engine. Higher numbers cause the throttling outputs to stay active for longer periods of time when the unit demands an increase or decrease in the throttling. If it hunts around the set-point, lower the setting. If the engine never reaches the set-point, raise the number. Factory set to 700.

S41 THR FDBK DLY

This set-point adjusts the amount of time in quarter seconds that the controller waits to sample the change made from the previous throttle pulse. Lower numbers cause less of a wait than larger numbers. If the system pressure, for example, takes quite a long time to change based on speed changes from the engine, this set-point should be increased. On the other hand, if the system pressure reacts quickly with changes in engine RPM, lower the set-point. Factory set to 2.

S42 THR SEN SITVY

This set-point adjusts the throttle sensitivity when it closes in on the desired set-point. Higher numbers cause it to make more coarse signal adjustments when approaching a set-point than lower numbers. This set-point is used to keep the unit from overshooting or undershooting a set-point. If it hunts around the set-point, lower the setting. If the engine never reaches the set-point, raise the number. Factory set to 700.

How to access the P-numbers

Also refer to the "Quick-reference" sheet supplied with this installation.

1. Press the ▼ button until the title page appears.
2. Press the ● button until the entry code screen appears.
3. Press the ▲ or ▼ buttons until the corresponding entry code is displayed.
4. Press the ● button once, the P-numbers main menu will be displayed.
5. Now that you are in the P-numbers, you can go to a specific function by pressing the ▲ or ▼ buttons then pressing the ● button to enter the specific function. Now you toggle, or acknowledge service reminders.

All P Numbers use the above described procedure. You can exit this mode by depressing and holding the ▼ button until the exit screen is displayed.

Now press ● to set the EMS back into the Main Displays. If you forget to exit the P-numbers menu, the EMS will exit for you after 10 minutes.

P-Numbers Description and Listings

The P-numbers are used to acknowledge service reminders and accessing the shutdown history list. Following is a list of P-number information and acknowledgments.

P0 CIRCLE = EXIT

Used to exit the P-number editing mode.

P1 LINE 1 SELECT

Used to change what is displayed on the top line throughout your P-number editing session. Your choices include: Engine Speed, Run Hours, Battery Voltage, Oil Pressure, and Engine Temperature.

P2 OIL PR @ SHDW

Shows what the engine oil pressure was when the unit initiated the last shutdown. To view the information, press the ● button.

P3 TEMP @ SHDW

Shows what the engine temperature was when the unit initiated the last shutdown. To view the information, press the ● button.

P4 TACH @ SHDW

Shows what the engine speed was when the unit initiated the last shutdown. To view the information, press the ● button.

P5 LAST SHUTDOWN

Shows what caused the last shutdown and the time in running hours that it occurred. To view the information, press the ● button.

P6 THRU P14 ## SHUTDWN

These P-numbers store the 2nd through the 10th cause of shutdown and the running hours they occurred (to view information, press ● button).

P15 ACK CHG OIL

This setting allows the user to acknowledge that they have changed the oil in the engine as prompted by the unit. When this setting is toggled from NO to YES, the unit resets the counter and will not prompt the user again until the selected number of running hours has elapsed.

P16 ACK OIL FLTR

This setting allows the user to acknowledge that they have changed the oil filter as prompted by the unit. When this setting is toggled from NO to

Double Checking your Wiring

The EMS Controller has built in diagnostic information for confirming your wiring before you attempt to auto start your engine. The diagnostic information is found in the S-numbers under S1 LINE 1 SELECT. The factory default line 1 display shows the engine RPM. By scrolling through the displays, you will see the following:

I 1-4 0000

This represents the 4 standard digital only inputs. A Ø means that the input is not active. An X means that the input is active. Following is what each input represents:

1. Auto Position on Toggle Switch
2. Test Position on Toggle Switch
3. External Spare 1 Shutdown input
4. Not Used for This Application

Next screen shows the rest of your inputs: I 5-12 0000 0000

5. Battery Voltage Input (ignore)
6. Temperature Sender (For test purposes, you can ground this input to make sure you have run your wire properly.)

7. Oil Pressure Sender (For test purposes, you can ground this input to make sure you have run your wire properly.)

8. Low Coolant Level Input

9. OPL Start Input / Remote S/S Input

10. OPL Stop Input

11. OPL Increase Input (low oil level in Manual mode)

12. OPL Decrease Input (V-belt break in Manual mode)

Next screen show your outputs: O 1-7 0000 000

1. Fuel Valve Output

2. Starter Circuit Output

3. Common Fail Output

4. Throttler Decrease Output

5. Throttler Increase Output

6. Prelube Output

7. Clutch Output

RS485 Output

This program is equipped with computer display capability. By hooking up to a computer equipped with an RS485 serial port and a communication program like Procomm Plus or Hyperterminal, you can remotely watch the status of your engine. The screen output consists of the Engine RPM, Oil Pressure, Engine Temperature, Running Hours, Target Engine RPM, Engine State, Selector Switch

Position, Current Service Reminders, and a shutdown history log. For proper display, set your communications package to 9600 baud N-8-1. Shown below is an example of the generic Input / Output layout for EMS447 and EMS448 models.

Oil pressure	100	PSI
Engine temperature	167	°F
Engine hours	93.5	
System voltage	14.0	
Engine rpm	1343	
Setpoint rpm	700	
SELECTOR - TEST		
WARMUP		
CHANGE OIL		
SHUTDOWN INFORMATION		
Hours at shutdown	93	
Oil pressure shutdown	11 psi	

EMS447 Pin and Color Codes to EMS448 Terminal Conversion

EMS447 PIN Num.	Color Code (Option -C)	447 Relay	EMS448 Terminal Designation	Input / Output Designation
1	Black		31	Analog input 4
4	Orange		37	Analog input 1
7†	Blue	K3	Com 1=B+ NO=8 NC=7 Com 2=18 NO=16 NC=17 (K6)	Digital output 1
9	Gray		20	Battery +
10†	Red w/ Black stripe	K2	Com 1=6 NO=4 NC=5 Com 2=15 NO=13 NC=14 (K2)	Digital output 2
12†	Red w/ Green stripe	K1	21 & 22 NO (K1)	Digital output 3
15	White w/ Brown stripe		34	Analog input 5
17	White w/ Blue stripe		38	Analog input 2
18	White w/ Green stripe		40	Digital input 3
19	White w/ Red stripe		12	Digital input 4 jumper
21	White w/ Orange stripe		25	Digital output 5
23	White w/ Gray stripe		29 & 30 NO (K7)	*Digital output 7 jumper
24	White		2	RS485 neg. - Comm.
25	White w/ Black/Red		3	RS485 pos. + Comm.

Notes: Digital output 4 can be equipped with EMS448 relay K3—provides N.O. dry contact output at terminals 23/24. Digital output 5 can be equipped with EMS448 relay K4—provides N.O. dry contact at terminals 25/26. *LK1 is on the "OUT" position for this program. †Pins 7,10, and 12 are battery positive, relay contact outputs from the EMS447 with LK4, 5, and 6 in the "R" position. LK2 positions 0-7 in "sender" position unless oil pressure "xducer" option chosen, then LK2-2 should be in 4-20 position.

EMS447 AUTOMATIC MODE Wiring Diagram (S23=Automatic)

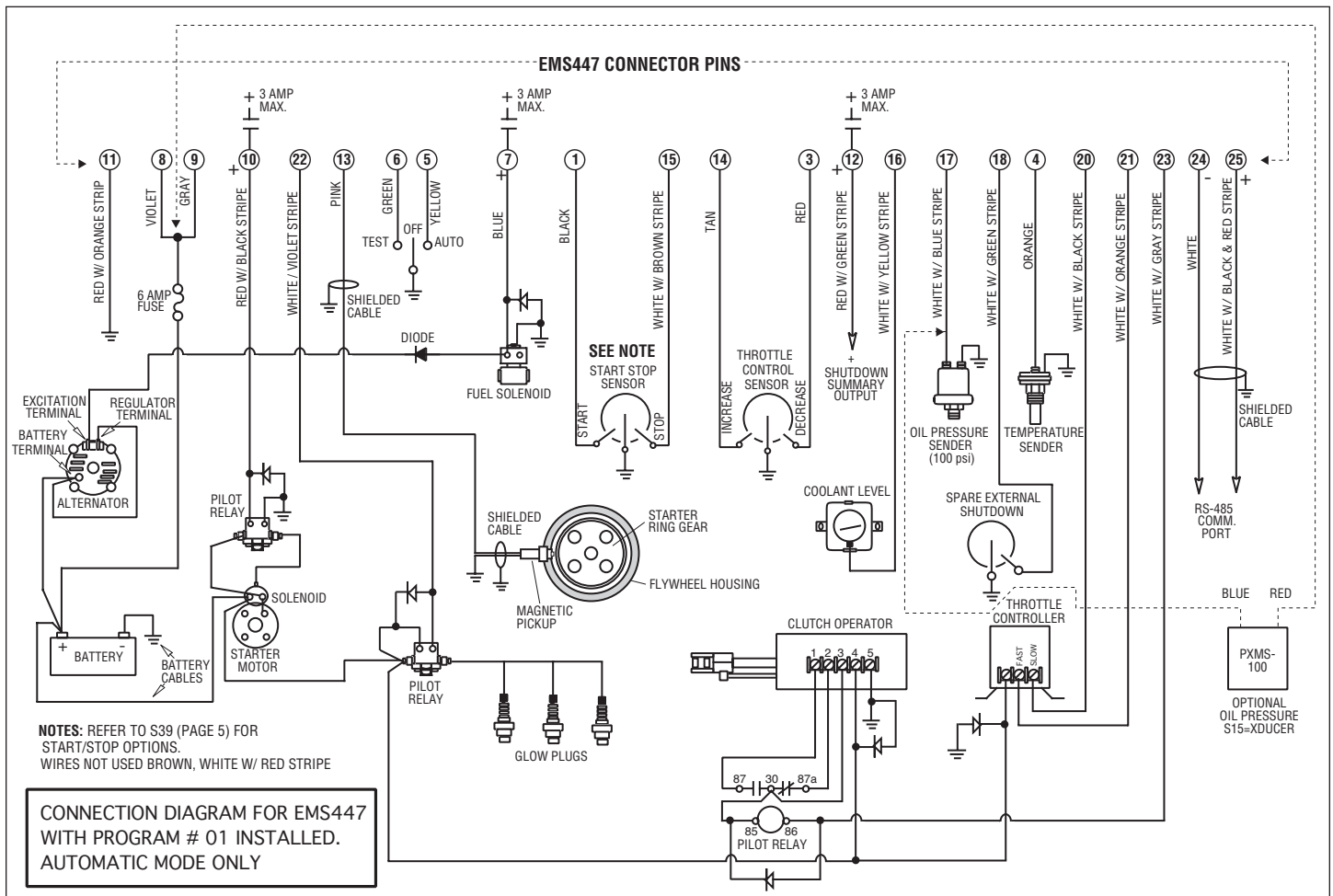

EMS447 MANUAL MODE Wiring Diagram (S23=Manual)

CONNECTION DIAGRAM FOR EMS447 WITH PROGRAM # 01 INSTALLED. MANUAL MODE ONLY

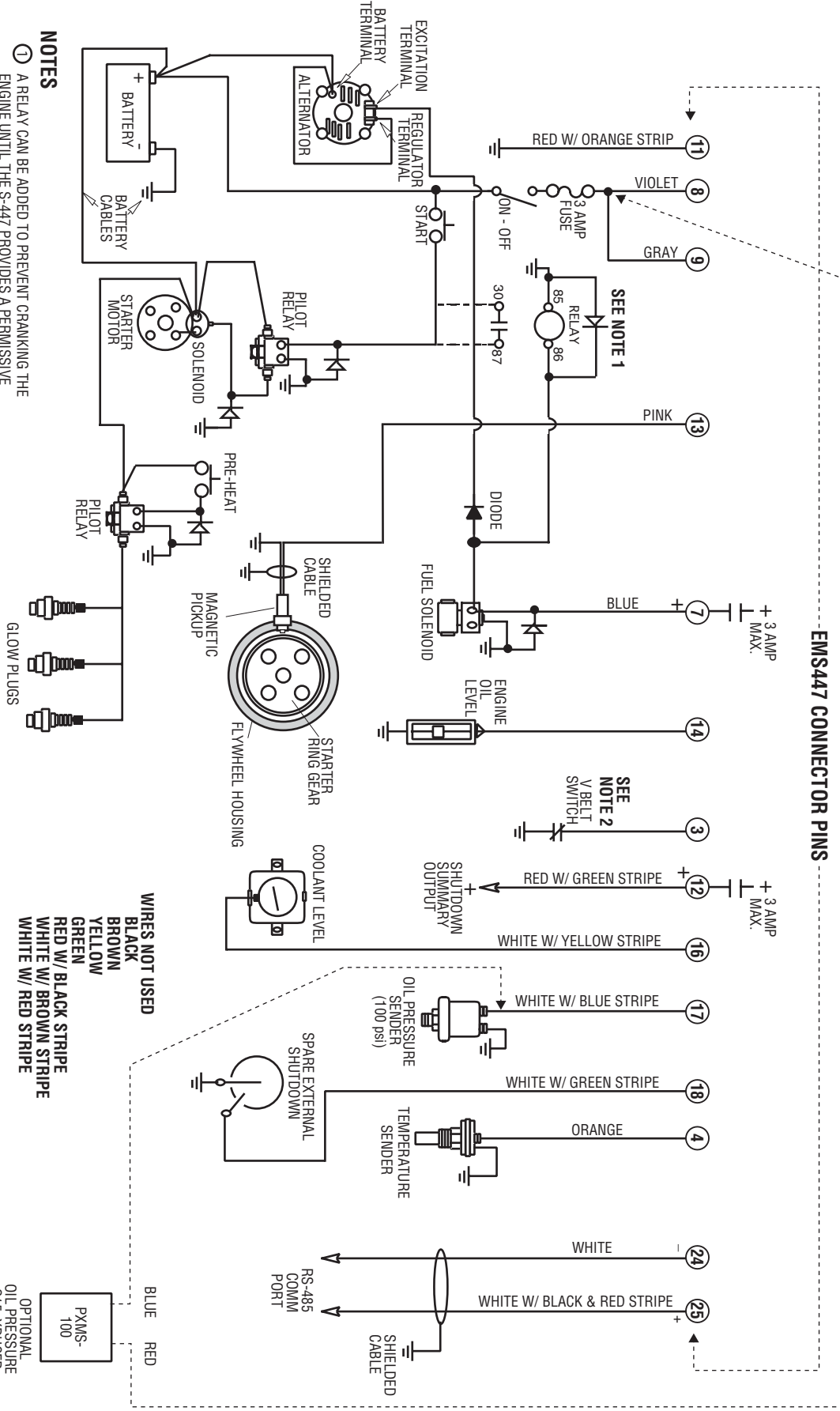

EMS447 CONNECTOR PINS

WIRES NOT USED
 BLACK
 BROWN
 YELLOW
 GREEN
 RED W/ BLACK STRIPE
 WHITE W/ BROWN STRIPE
 WHITE W/ RED STRIPE

OPTIONAL OIL PRESSURE S15=XDUCER

BLUE
 RED

EMS448 AUTOMATIC MODE Wiring Diagram (S23=Automatic)

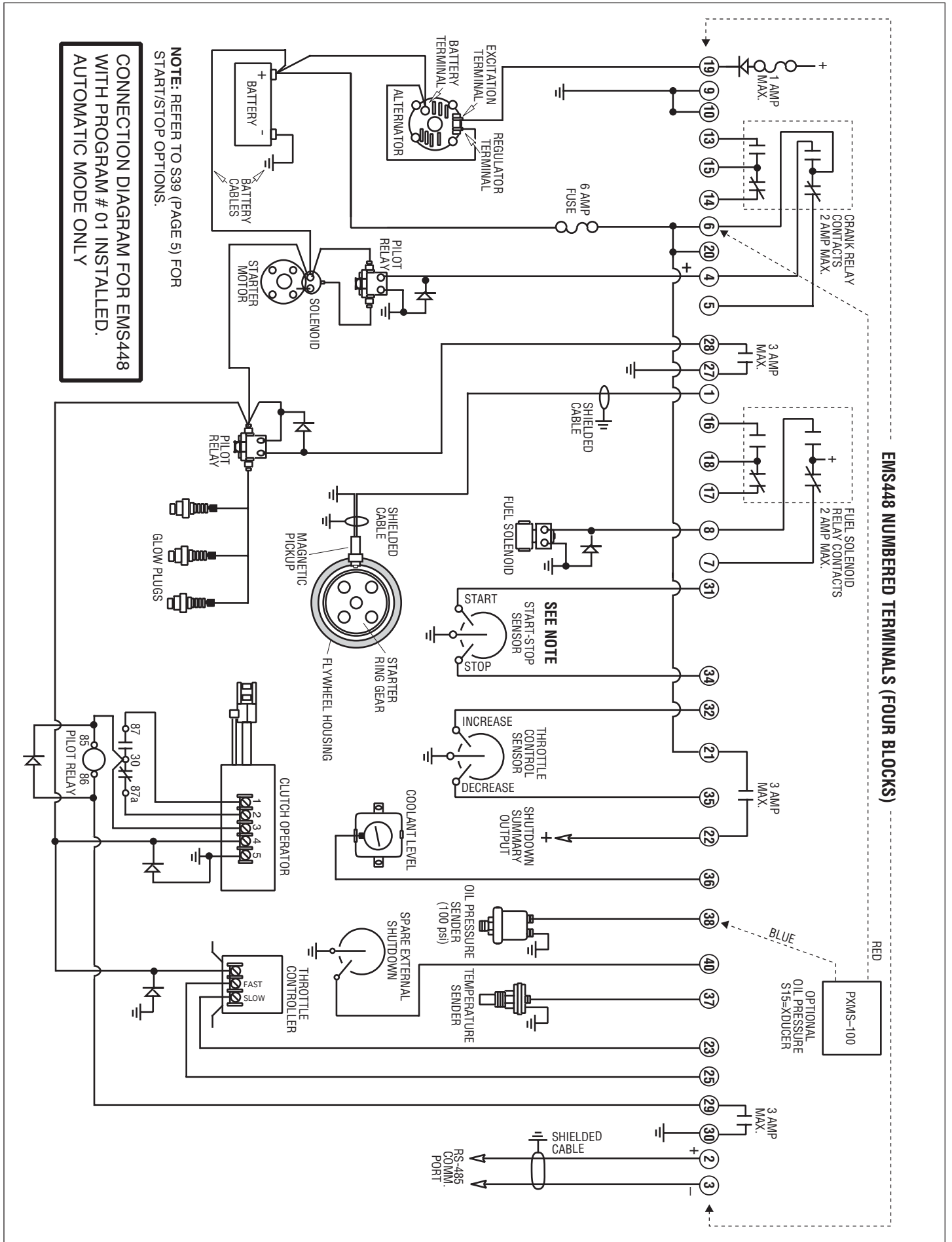

CONNECTION DIAGRAM FOR EMS448 WITH PROGRAM # 01 INSTALLED. AUTOMATIC MODE ONLY

NOTE: REFER TO S39 (PAGE 5) FOR START/STOP OPTIONS.

EMS448 MANUAL MODE Wiring Diagram (S23=Manual)

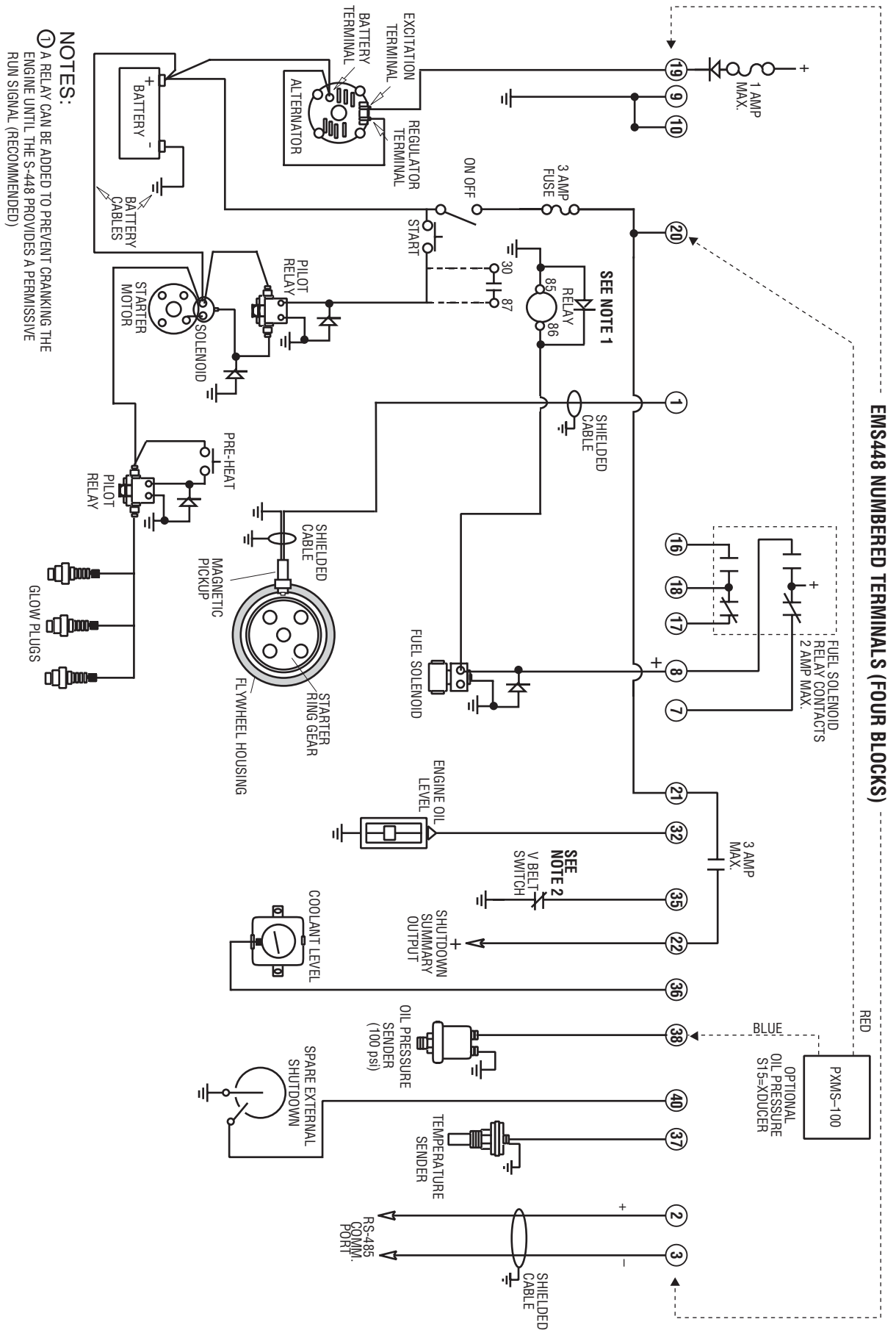

EMS448 NUMBERED TERMINALS (FOUR BLOCKS)

NOTES:

- ① A RELAY CAN BE ADDED TO PREVENT CRANKING THE ENGINE UNTIL THE S-448 PROVIDES A PERMISSIVE RUN SIGNAL (RECOMMENDED)
- ② IF A V BELT SWITCH IS NOT USED, GROUND TERMINAL #35

CONNECTION DIAGRAM FOR EMS448 WITH PROGRAM # 01 INSTALLED. MANUAL MODE ONLY

Quick Wiring Reference for Automatic Mode

Pin Number	Customer Hookup
1.	Momentary Start or Sustained Start/Stop Contact (ground only).
2.	No Customer Hookup.
3.	Throttle Control Sensor Input (Decrease) (ground only).
4.	Temperature Sender Input.
5.	Auto Position of T-O-A Switch Input (positive or ground input).
6.	Test Position of T-O-A Switch Input (positive or ground input).
7.	Fuel Solenoid Output (Battery + 3 A max.).
8.	Battery Plus (+) 12 or 24 VDC.
9.	Battery Plus (+) 12 or 24 VDC.
10.	Starter Output (Battery + 3 A max.).
11.	Battery Ground(-).
12.	Shutdown Summary Output (Battery + 3 A max.).
13.	Magnetic Pickup Input (2 Vrms minimum).
14.	Throttle Control Sensor Input (Increase) (ground only).
15.	Momentary Stop Input or 2nd maintain to start/stop input (ground only).
16.	Low Coolant Level Input (ground).
17.	Oil Pressure Sender Input (or PXMS-100 Blue Wire).
18.	Spare External Shutdown 1 Input (positive or ground).
19.	Not Used For This Application.
20.	Throttle Controller Slow Output (sinking-125 mA max.).
21.	Throttle Controller Fast Output (sinking-125 mA max.).
22.	Prelube/Glowplug Output (sinking-125 mA max.).
23.	Clutch Operator Output (sinking-125 mA max.).
24.	RS485-.
25.	RS485 +.

NOTE:

*EMS 447 LK1=OUT, LK2 (0-7)=SENDER
(Except LK2-2 IF S15=XDUCER, LK2-2= 4-20)
LK4, 5, and 6=R*

Terminal	Customer Hookup
1.	Magnetic Pickup Input (2 Vrms minimum).
2.	RS485 +.
3.	RS485 -.
4.	N.O. Starter Output (2 A max)
5.	N.C. Starter Output (2 A max).
6.	Common Terminal of Starter Output.
7.	N.C. Fuel Valve Output (Battery+ 2 A max.).
8.	N.O. Fuel Valve Output (Battery+ 2 A max.).
9.	Battery Ground (-).
10.	Battery Ground (-).
11.	Test Position of T-O-A Switch Input (positive or ground input).
12.	Not Used For This Application.
13.	Aux. N.O. Starter Contact (2 A max.).
14.	Aux. N.C. Starter Contact (2 A max.).
15.	Aux. Common Starter Terminals.
16.	Aux. N.O. Fuel Valve Output (2 A max.).
17.	Aux. N.C. Fuel Valve Output (2 A max.).
18.	Aux. Common Fuel Valve Output (2 A max.).
19.	Fused (1 A) Battery Plus output for alternator excitation.
20.	Battery Plus (+) 12 or 24 VDC.
21.	Shutdown Summary Output N.O. Contact (3 A max.).
22.	Shutdown Summary Output Common Contact (3 A max.).
23.	Throttle Controller Decrease Out (sinking: 125 mA max.).
24.	Not Used For This Application.
25.	Throttle Controller Increase Out (Sinking: 125 mA max.).
26.	Not Used for This Application.
27.	Prelube / Glowplug Output Dry Contact N.O. (3 A max.).
28.	Prelub / Glowplug Output Dry contact Common (3 A max.).
29.	Clutch Output Dry Contact N.O. (3 A max.).
30.	Clutch Output Dry Contact Common (3 A max.).
31.	Momentary Start or Sustained Start/Stop Contact (ground only).
32.	Throttle Control Sensor Increase Input (ground only).
33.	No Customer Hookup.
34.	Momentary Stop Input or 2nd maintain to start / stop input (ground only).
35.	Throttle Control Sensor Decrease Input (ground only).
36.	Coolant Level Input (ground only).
37.	Temperature Sender Input.
38.	Oil Pressure Sender Input (or PXMS-100 Blue Wire).
39.	Auto Position of T-O-A Switch Input (positive or ground input).
40.	Spare External Shutdown 1 Input (positive or ground).

NOTE:

*EMS 448 LK1=OUT, LK2 (0-7)=SENDER
(Except LK2-2 IF S15=XDUCER, LK2-2= 4-20)*

Quick Wiring Reference for Manual Mode

EMS447 Models

Pin Number	Customer Hookup
1.	No Customer Hookup.
2.	No Customer Hookup.
3.	V-belt Break Input N.C. (ground only).
4.	Temperature Sender Input.
5.	No Customer Hookup.
6.	No Customer Hookup.
7.	Fuel Valve Output (Battery + 3 A max.).
8.	Battery Plus (+) 12 or 24 VDC.
9.	Battery Plus (+) 12 or 24 VDC.
10.	No Customer Hookup.
11.	Battery Ground(-).
12.	Shutdown Summary Output (Battery + 3 A max.).
13.	Magnetic Pickup Input (2 Vrms minimum).
14.	Engine Oil Level Input (ground only).
15.	No Customer Hookup.
16.	Low Coolant Level Input (ground).
17.	Oil Pressure Sender Input (or PXMS-100 Blue Wire).
18.	Spare External Shutdown Input (positive or ground).
19.	Not Used For This Application.
20.	No Customer Hookup.
21.	No Customer Hookup.
22.	No Customer Hookup.
23.	No Customer Hookup.
24.	RS485-.
25.	RS485 +.

NOTE:

EMS 447 LK1=OUT, LK2 (0-7)=SENDER
 (Except LK2-2 IF S15=XDUCER, LK2-2= 4-20)
 LK4, 5, and 6=R

Warranty

A limited warranty on materials and workmanship is given with this FW Murphy product. A copy of the warranty may be viewed or printed by going to www.fwmurphy.com/support/warranty.htm

EMS448 Models

Terminal	Customer Hookup
1.	Magnetic Pickup Input (2 Vrms minimum).
2.	RS485 +.
3.	RS485 -.
4.	No Customer Hookup.
5.	No Customer Hookup.
6.	No Customer Hookup.
7.	N.C. Fuel Valve Output (Battery+ 2 A max.).
8.	N.O. Fuel Valve Output (Battery+ 2 A max.).
9.	Battery Ground (-).
10.	Battery Ground (-).
11.	No Customer Hookup.
12.	Not Used For This Application.
13.	No Customer Hookup.
14.	No Customer Hookup.
15.	No Customer Hookup.
16.	No Customer Hookup.
17.	No Customer Hookup.
18.	No Customer Hookup.
19.	Fused (1 A) Battery Plus output for alternator excitation.
20.	Battery Plus (+) 12 or 24 VDC.
21.	Shutdown Summary Dry Contact N.O. (3 A max.).
22.	Shutdown Summary Dry Contact Common (3 A max.).
23.	No Customer Hookup.
24.	No Customer Hookup.
25.	No Customer Hookup.
26.	No Customer Hookup.
27.	No Customer Hookup.
28.	No Customer Hookup.
29.	No Customer Hookup.
30.	No Customer Hookup.
31.	No Customer Hookup.
32.	Engine Oil Level (ground only).
33.	No Customer Hookup..
34.	No Customer Hookup.
35.	V-belt Break Input (N.C.) (ground only).
36.	Coolant Level Input (ground only).
37.	Temperature Sender Input.
38.	Oil Pressure Sender Input (or PXMS-100 Blue Wire).
39.	No Customer Hookup.
40.	Spare External Shutdown Input (positive or ground).

NOTE:

EMS 448 LK1=OUT, LK2 (0-7)=SENDER
 (Except LK2-2 IF S15=XDUCER, LK2-2= 4-20)



FW Murphy
 P.O. Box 470248
 Tulsa, Oklahoma 74147 USA
 +1 918 317 4100
fax +1 918 317 4266
e-mail sales@fwmurphy.com
www.fwmurphy.com

CONTROL SYSTEMS & SERVICES DIVISION
 P.O. Box 1819; Rosenberg, Texas 77471; USA
 +1 281 633 4500 **fax** +1 281 633 4588
e-mail sales@fwmurphy.com

MURPHY DE MEXICO, S.A. DE C.V.
 Blvd. Antonio Rocha Cordero 300, Fracción del Aguaje
 San Luis Potosí, S.L.P.; México 78384
 +52 444 8206264 **fax** +52 444 8206336
 Villahermosa Office +52 993 3162117
e-mail ventas@murphymex.com.mx
www.murphymex.com.mx

FRANK W. MURPHY, LTD.
 Church Rd.; Laverstock, Salisbury SP1 1QZ; U.K.
 +44 1722 410055 **fax** +44 1722 410088
e-mail sales@fwmurphy.co.uk
www.fwmurphy.co.uk

MURPHY SWITCH OF CALIFORNIA
 41343 12th Street West
 Palmdale, California 93551-1442; USA
 +1 661 272 4700 **fax** +1 661 947 7570
e-mail sales@murphyswitch.com
www.murphyswitch.com

MACQUARRIE CORPORATION
 1620 Hume Highway
 Campbellfield, Vic 3061; Australia
 +61 3 9358 5555 **fax** +61 3 9358 5558
e-mail murphy@macquarrie.com.au



In order to consistently bring you the highest quality, full featured products, we reserve the right to change our specifications and designs at any time.

Printed in U.S.A.



CONFIDENTIAL

SECURITY ACCESS CODES

INFORMATION



MURPHY has made efforts to ensure the reliability of the EMS447 and EMS448 Systems. Please note that the EMS447 and EMS448 Set Up numbers (S-Numbers and P-Numbers) are critical operating parameters. These numbers contain information that only qualified personnel should be allowed to access.

Items set improperly within these parameters can cause serious damage to the EMS447 / 448 and to your equipment.

Access to the S-Numbers and P-Numbers is password protected. Please keep these access codes away from unauthorized personnel. The access codes are designated as follows:

S-Numbers access code = 64

P-Numbers access code = 61

Read all instructions before attempting to edit the S-Numbers or the P-Numbers, and make sure that the device is correctly installed.

Please contact Murphy if you have any questions.

QUICK REFERENCE CHART

NOTE: Screens are shown for reference only. Your EMS screens may vary depending on the program used.

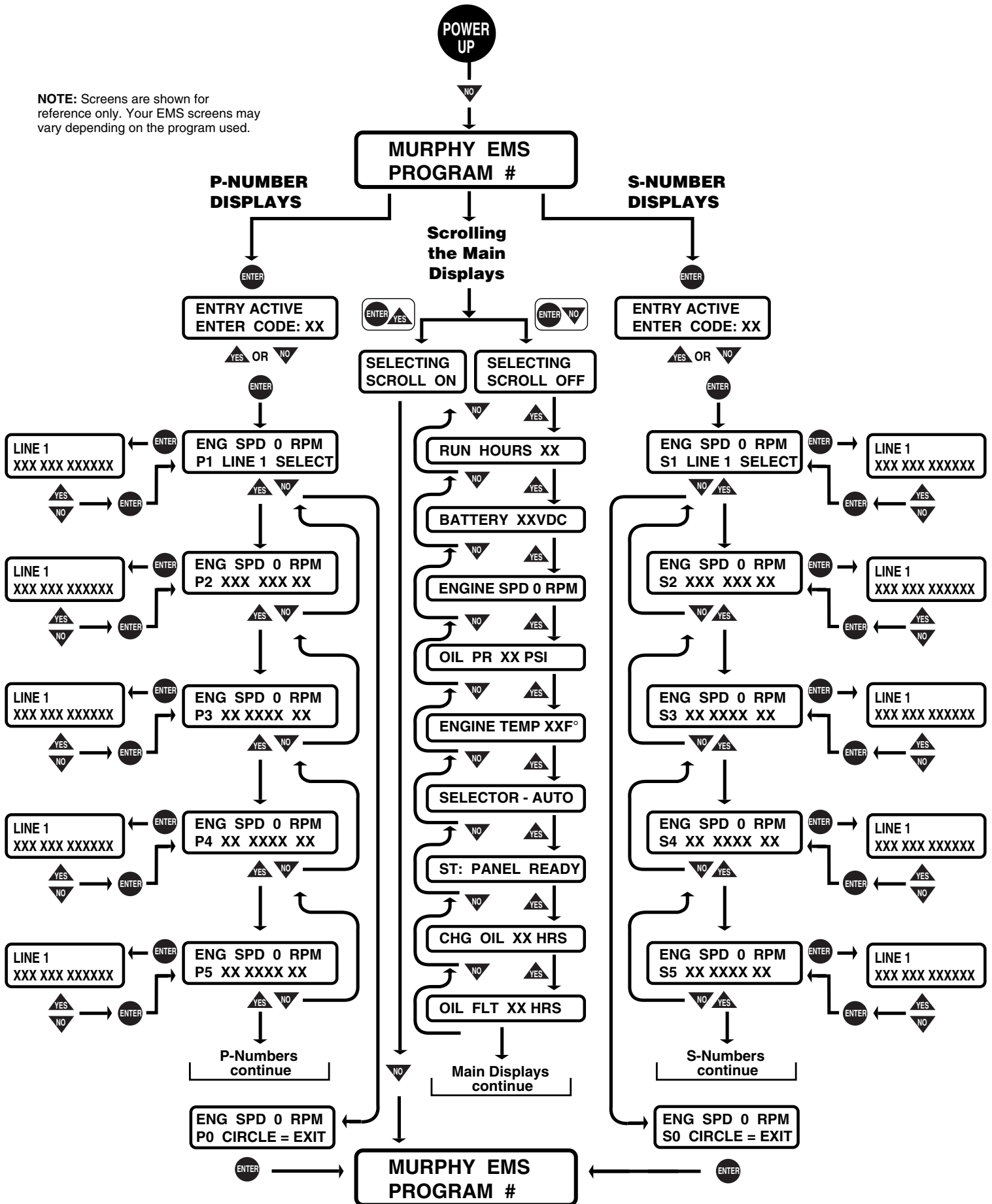

YES, the unit resets the counter and will not prompt the user again until the selected number of running hours has elapsed.

P17 ACK FUEL FLTR

This setting allows the user to acknowledge that they have changed the fuel filter as prompted by the unit. When this setting is toggled from NO to YES, the unit resets the counter and will not prompt the user again until the selected number of running hours has elapsed.

P18 ACK AIR CLNR

This setting allows the user to acknowledge that they have changed or serviced the air cleaner as prompted by the unit. When this setting is toggled from NO to YES, the unit resets the counter and will not prompt the user again until the selected number of running hours has elapsed.

P19 ACK BATTERY

This setting allows the user to acknowledge that they have serviced / changed the battery as prompted by the unit. When this setting is toggled from NO to YES, the unit resets the counter and will not prompt the user again until the selected number of running hours has elapsed.

P20 PROGRAM #

This indicates what program and version number is installed in your unit. When you call for help, please have this number available.

General Wiring Precautions

There are several precautions you can take on initial installation to increase reliability. Many of these steps may take a few extra minutes to do at the time of installation; however, they can also save headaches in the future. We strongly recommend that you follow these precautionary steps.

1. Suppression Diodes

Place suppression diodes across all inductive loads. These loads typically include pilot relays, solenoid valves, starter solenoids, etc. This helps increase contact life and eliminate a source of electrical interference.

2. Wire Power Leads Directly to Battery Post

When hooking your power supply to your EMS447 /448 (Automatic mode) or Off-On switch (Manual Mode), run your positive and negative wiring directly to the battery posts. This helps minimize noise generated from battery chargers and alternators.

3. Pilot Excessive Loads

Many of the outputs on the EMS controller are rated for low current, control type loads. Do NOT run high current loads directly to the unit.

4. Use Stranded Wire for Hook Up

Solid wire transmits vibration and is more likely to crystallize and break when it is subjected to movement and or vibration.

5. Wire Standby Battery Charger Directly to Battery

Standby chargers must be wired directly to the battery. Failing to do this may result in erratic operation due to electric “noise” coupled into the microprocessor.

6. Separate VAC and VDC Wiring

Never run AC and DC handling wiring together. AC signals may get coupled into the control circuits leading to erratic operation.

7. Special Precaution for Spark Ignition Systems

Spark ignition systems produce high voltage and cause high frequency interference. Precautions must be taken to protect the EMS. All wiring, and especially sender and shutdown wiring must be routed away from the ignition and spark plug wiring. Resistor spark plugs and spark plug wires reduce electrical interference and are recommended for these applications.

8. Use Shielded Cable on Magnetic Pick-up

Shielded cable is recommended for connecting the magnetic pick-up to the unit. This helps prevent signal loss and possible coupling of electrical interference into the relatively sensitive speed sensing circuit. The shield should only be grounded on one end. Remember, proper care during installation will help your EMS controller live a long and trouble-free operating life.