

Four-Function Annunciator TATTLETALE®

00-02-0268
Revised 07-99
Catalog Section 70



EN204 Series

- Designed for Use with Electric SWICHGAGE®s or Normally Open, Close to Negative Contacts
- LED Annunciation for Low Oil Pressure, High Water Temperature, Loss of Battery Voltage, and Low Fuel Level or Glow Plug.
- Output may be used for Tripping an Electromagnetic Control Switch for Engine Shutdown
- Developed with the Same Leading Edge Technology as Our EGS Series Electric SWICHGAGE®

Description

Murphy's EN204 Annunciator TATTLETALE® works with other engine components to clearly indicate critical engine operating conditions. The four bright LEDs on the face of the Annunciator indicate the cause of an alarm or shutdown condition.

Two EN204 models are available. Each shows the standard critical engine operating parameters—oil pressure, coolant temperature, and battery voltage. Model EN204-S-12 also includes an indicator for low fuel level. Model EN204-SG-12 substitutes the fuel level indicator with a glow plug indicator for those engines that use a glow plug for easier starting.

The EN204 Annunciators are used in conjunction with Murphy Electric SWICHGAGE®s or other normally open switches that close to ground when a fault condition occurs. As an example, in a system with a Murphy EGS21P-100 Oil Pressure SWICHGAGE®, the SWICHGAGE® closes to ground when the oil pressure drops below a pre-determined set point. This will energize the Oil Pressure LED on the EN204 to highlight a low oil pressure failure.

A very important feature of the EN204 is the ability to interface with Murphy 518PH or the 760A Electromagnetic Switches to perform automatic engine shutdown when fault conditions occur. The EN204 can also be used with other Murphy visual and audible alarms (STAS series remote alarm, SAH audible alarm, and the TL7 visual alarm) for remote annunciation and equipment shutdown.

Basic Models

The following two basic models are offered:

EN204-S-12		EN204-SG-12	
Monitored Functions	Action	Monitored Functions	Action
Oil Pressure	Indicate and Switched	Oil Pressure	Indicate and Switched
Coolant Temperature	Indicate and Switched	Coolant Temperature	Indicate and Switched
Battery Voltage	Indicate	Battery Voltage	Indicate
Fuel Level	Indicate and Switched	Glow Plug Energized	Indicate

The **Switched** functions listed above are able to sink a current up to 0.275 amps and may be used to activate the electromechanical control switches or other devices.

Specifications

Operating Voltage:

12 VDC (10 V min. - 16 V max.).

Current:

0.020 A to 0.025 A per LED.

Output:

Sink 0.275 A.

Output Saturation Voltage:

.7-1.1 V @ 25°C.

Case and Screw-on Mounting Clamp:

Polyester (PBT).

Bezel:

Bright stainless steel.

Lens:

Clear Polycarbonate, UV stabilized.

Dial:

Black background and white markings with four (4) Red LED indicators.

Wiring:

Plug connector with wire leads, 18 AWG (1.0 mm²) x 8 in. (203 mm) long.

Operating Temperature:

-40 to 185°F (-40 to +85°C).

Storage Temperature:

-76 to 185°F (-60 to 85°C).

Shipping Weight:

0.5 lb. (226 g).

Shipping Dimensions:

8 x 4 x 4-1/2 in. (203 x 102 x 114 mm).

How to Order

EN204-S-12 and switch

Four LED TATTLETALE® including Fuel Level LED indicator.

EN204-SG-12

Four LED TATTLETALE® including Glow Plug LED indicator.



Dimensions

Front View

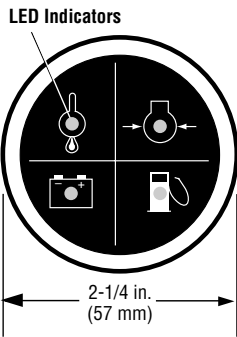

Side View

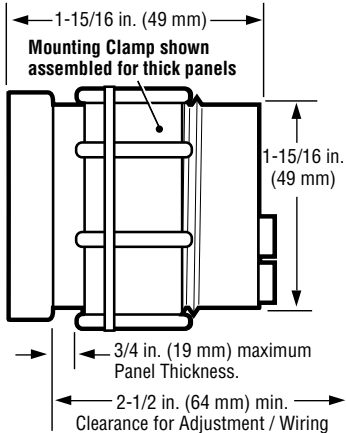

Back View

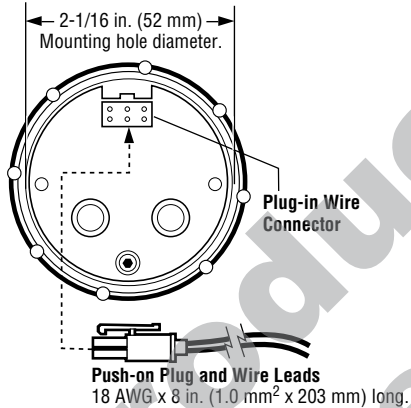

EN204-S Typical Wiring Diagram



WARNING: Turn the power source OFF before wiring.

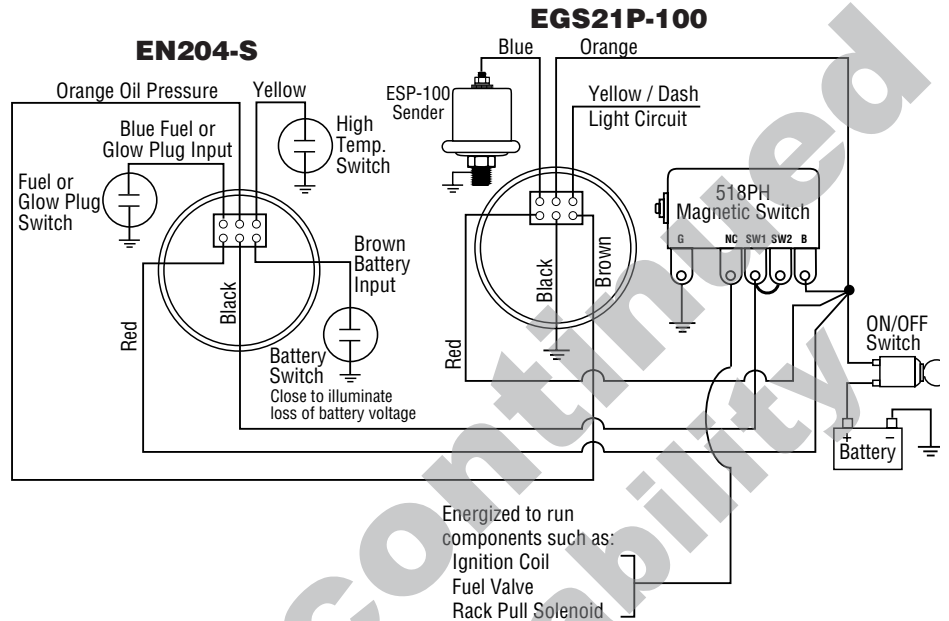

Note: Use of the **black wire** on the **EN204-S** and the **518PH Magnetic Switch** (as shown in the diagram) is required for engine shutdown. For LED annunciation only, **black wire** is not used.

Warranty

A limited warranty on materials and workmanship is given with this FW Murphy product. A copy of the warranty may be viewed or printed by going to www.fwmurphy.com/support/warranty.htm

MURPHY

FW Murphy

P.O. Box 470248
Tulsa, Oklahoma 74147 USA
+1 918 317 4100 fax +1 918 317 4266
e-mail sales@fwmurphy.com
www.fwmurphy.com

INDUSTRIAL PANEL DIVISION

P.O. Box 470248
Tulsa, Oklahoma 74147 USA
+1 918 317 4100 fax +1 918 317 4266
e-mail sales@fwmurphy.com

MURPHY DE MEXICO, S.A. DE C.V.

Blvd. Antonio Rocha Cordero 300, Fracción del Aguaje
San Luis Potosí, S.L.P.; México 78384
+52 444 8206264 fax +52 444 8206336
Villahermosa Office +52 993 3162117
e-mail ventas@murphymex.com.mx
www.murphymex.com.mx

FRANK W. MURPHY, LTD.

Church Rd.; Laverstock, Salisbury SP1 1GZ; U.K.
+44 1722 410055 fax +44 1722 410088
e-mail sales@fwmurphy.co.uk
www.fwmurphy.co.uk



ISO 9001
REGISTERED

Printed in U.S.A.

In order to consistently bring you the highest quality, full featured products, we reserve the right to change our specifications and designs at any time.