

MURPHY®



PowerView™ Model PV1000

Hardware Installation Manual

00-02-0599
07-19-07
Section 78

In order to consistently bring you the highest quality, full featured products, we reserve the right to change our specifications and designs at any time. The latest version of this manual can be found at www.fwmurphy.com.

Warranty - A limited warranty on materials and workmanship for one year is given with this FW Murphy product. A copy of the warranty may be viewed or printed by going to www.fwmurphy.com/support/warranty.htm



Please read the following information before installing.

BEFORE BEGINNING INSTALLATION OF THIS MURPHY PRODUCT:

- Read and follow all installation instructions.
- Disconnect all electrical power to the machine.
- Make sure the machine cannot operate during installation.
- Follow all safety warnings of the machine manufacturer.
- Please contact FW MURPHY immediately if you have any questions.

Table of Contents

Product Information	1
Inspecting Package Contents.....	1
Hardware Installation	2
Dash-Mounted Installation.....	2
Gimbal Mount Installation.....	3
Wiring Instructions	4
Single Engine	4
Dual Engine Static Addressing.....	5
NMEA Wiring.....	6
PVA Gages	7
Pin Specifications for Deutsch DT04-6P Style Connections.....	8
Wiring Schematic	9
Specifications	10

PHASE OUT / DISCONTINUED
Check Availability

(THIS PAGE INTENTIONALLY LEFT BLANK)

PHASE OUT / DISCONTINUED
Check Availability

Product Information

The PowerView™ display is designed for instrumentation on electronically controlled engines communicating using the SAE J1939 Controller Area Network (CAN), NMEA 2000 (GPS features) or a proprietary blend of protocols. The PowerView display is a multifunction tool that enables operators to view many different engine, equipment, or transmission parameters and service codes, and can support many devices simultaneously.

Two mounting options are provided for the display. The in-dash mounting option requires a hole to be cut for insertion of the display. A plastic installation template P/N 78000386 is included in the box and a drawing is also provided in the back of this document.

The gimbal-mount method enables the display to be installed on a flat surface. Its design allows you to rotate and tilt the unit for the best display position for the operator's viewing.

NOTE: Please read the PV1000 Operations Manual for detailed instruction on the use and operation of the display.

Inspecting Package Contents

Before attempting to install the product, it is recommended that you ensure all parts are accounted for and inspect each item for damage (which sometimes occurs during shipping). The items included in the box are:

- PV1000 unit
- front cover snap on – P/N 78-05-0302
- installation kit – P/N 78-00-0386 includes:
 - 8 mounting screws and nuts
 - extra SD card cover
 - back plate (can be used as mounting template)
- Installation manual
- Operations manual

Hardware Installation

The following instructions will guide you through installing the PowerView display.

Dash-Mounted Installation

Tools needed.

- Drill with 9/64" size bit
- Jig Saw
- Wrench or socket for #6 Keps locking nuts (provided) to studs

Preparing the Dash

Determine the location of the PowerView in the dash. Use the Installation Template (included in the box) as a guideline to cut a hole in the dash to the specified dimensions. Drill holes where indicated on the template for the mounting screws.

NOTE: Use the plastic template included in the box whenever possible.

If you must use the paper template from the manual and you downloaded this document from the FW Murphy website, be aware that the pdf file may not automatically print to scale. When submitting the file for print, you will need to select "None" for Page Scaling. Check the accuracy of the printed template by verifying the measurements labeled on the template are correct.

If this manual was supplied with your product, the template will be correct.

Mounting the Unit

1. Attach the eight threaded studs to the back of the PowerView case.
2. Place the back side of the display through the opening in the dash.
3. Use the studs to line up the unit with the drilled holes.
4. Push the unit through the opening and studs through the drilled holes until the back of the case is flush.
5. Use the #6 Keps locking nuts provided to tighten unit to the dash. Use the appropriate wrench or socket to tighten. Torque lock nuts to 8-10 inch pounds.

Gimbal Mount Installation

Tools Needed

- Flathead or Phillips Screwdriver (depending upon screws used for mounting)
- Drill with 9/64" size bit
- Hole saw
- Three (3) 6-32 stainless panhead screws (self tapping or machine screws) (length = panel thickness + 0.125")

Mounting the Unit

1. Determine where the gimbal mount will be located on the dash. Attach the PowerView to the gimbal mount and tighten the adjustment knob to hold in place.
2. Mark the screw holes needed for the mount.
3. Drill holes for the mount.
4. Create a "pass-through" hole for the wires from the unit. This hole can be partially hidden by the triangle base of the gimbal mount

IMPORTANT! Be sure to smooth edges and install some type of cable protection to prevent cable chaffing, cuts and abrasions. Not taking this step could result in failures.

5. Pull the wires through the hole for connection.
6. Attach gimbal with the bolt and nut provided.

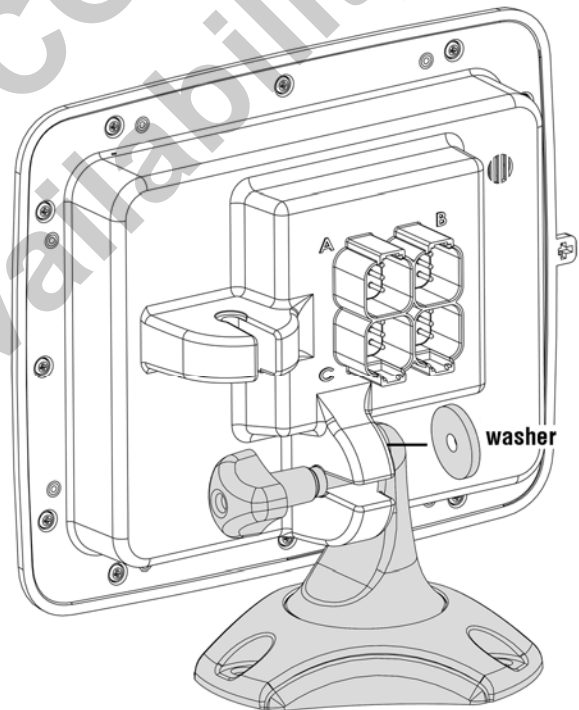

Gimbal Mount

Wiring Instructions

The following illustrations are examples of various typical quick-connect options for 1 or 2 engine setups and gages. Wiring harnesses are sold separately.

Single Engine

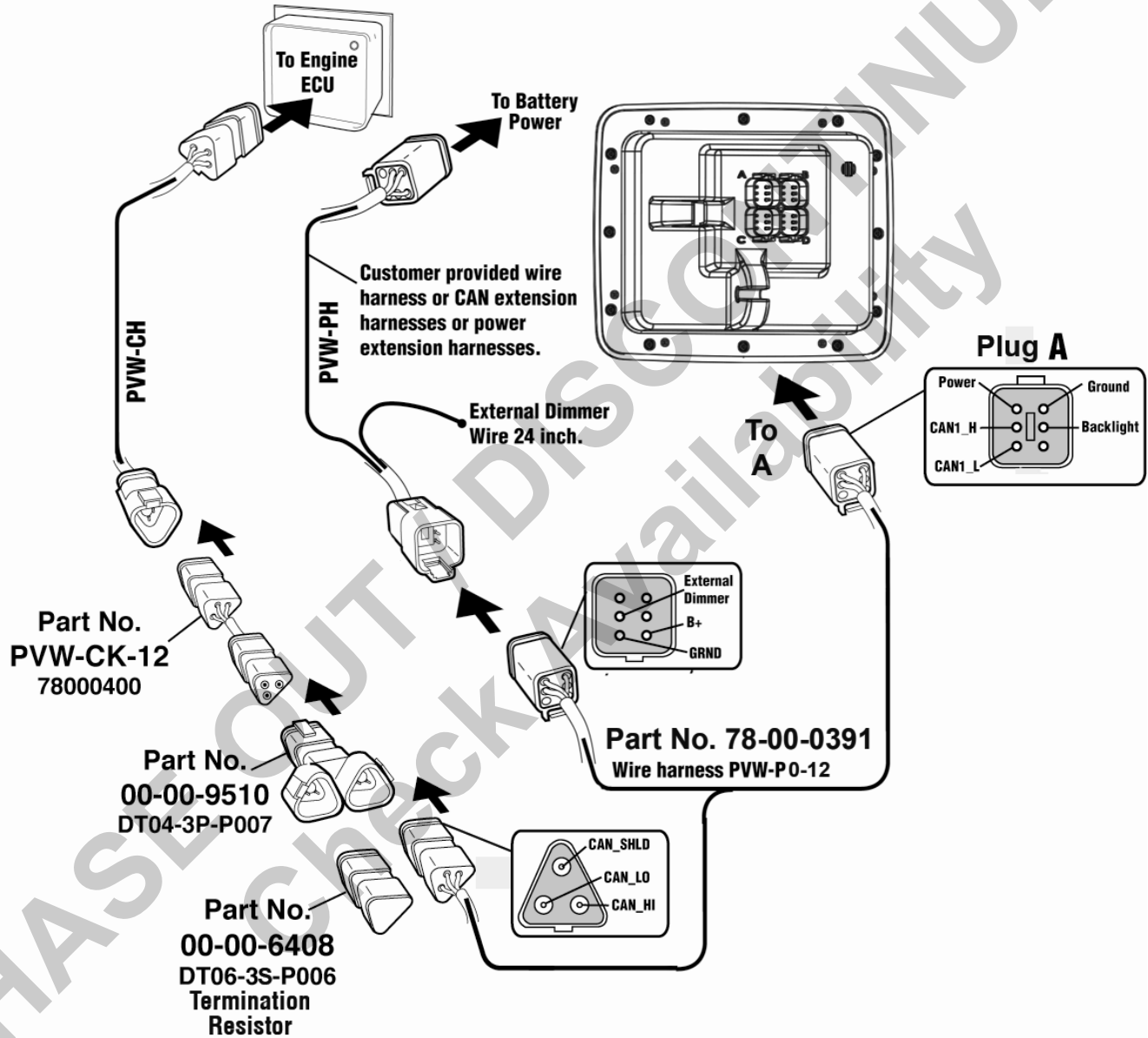

Software Configuration for Single Engine Setup

To set the software configuration for single engine, on the System Settings screen, under Wiring Configuration, select **Engine(s) – Single Harness to Plug A – Engine 1, Engine 2**.

Dual Engine Static Addressing

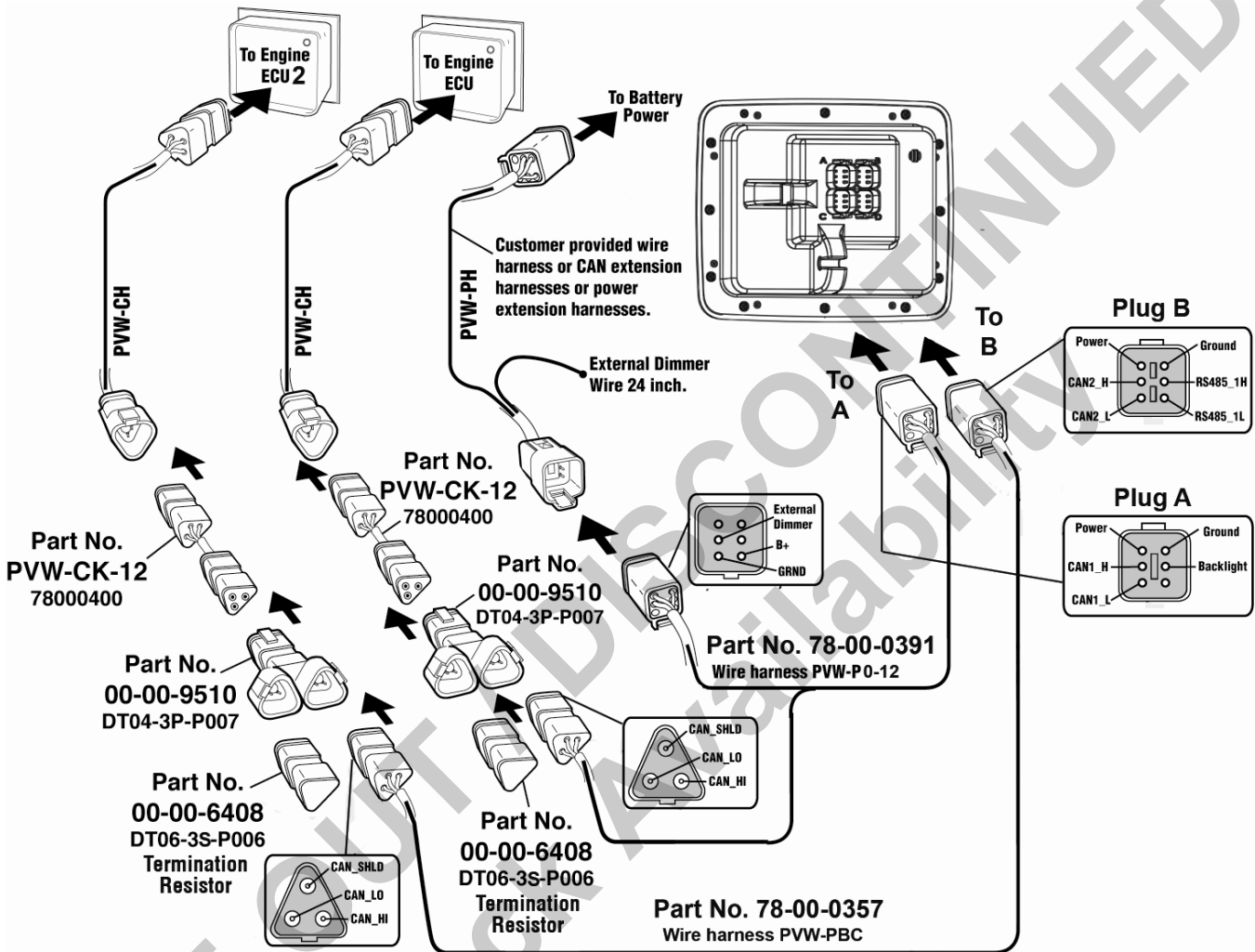

NOTE: Port A and B have different connector keys to ensure proper connection.

All cables are black with the exception of cables for Port B, which are yellow.

Software Configuration for Dual Engine Static Addressing

To set the software configuration for dual engine static addressing, on the System Settings screen, under Wiring Configuration, select **Engine(s) – Dual Harness to Plug A & B – Engine1, Engine 2.**

NMEA Wiring

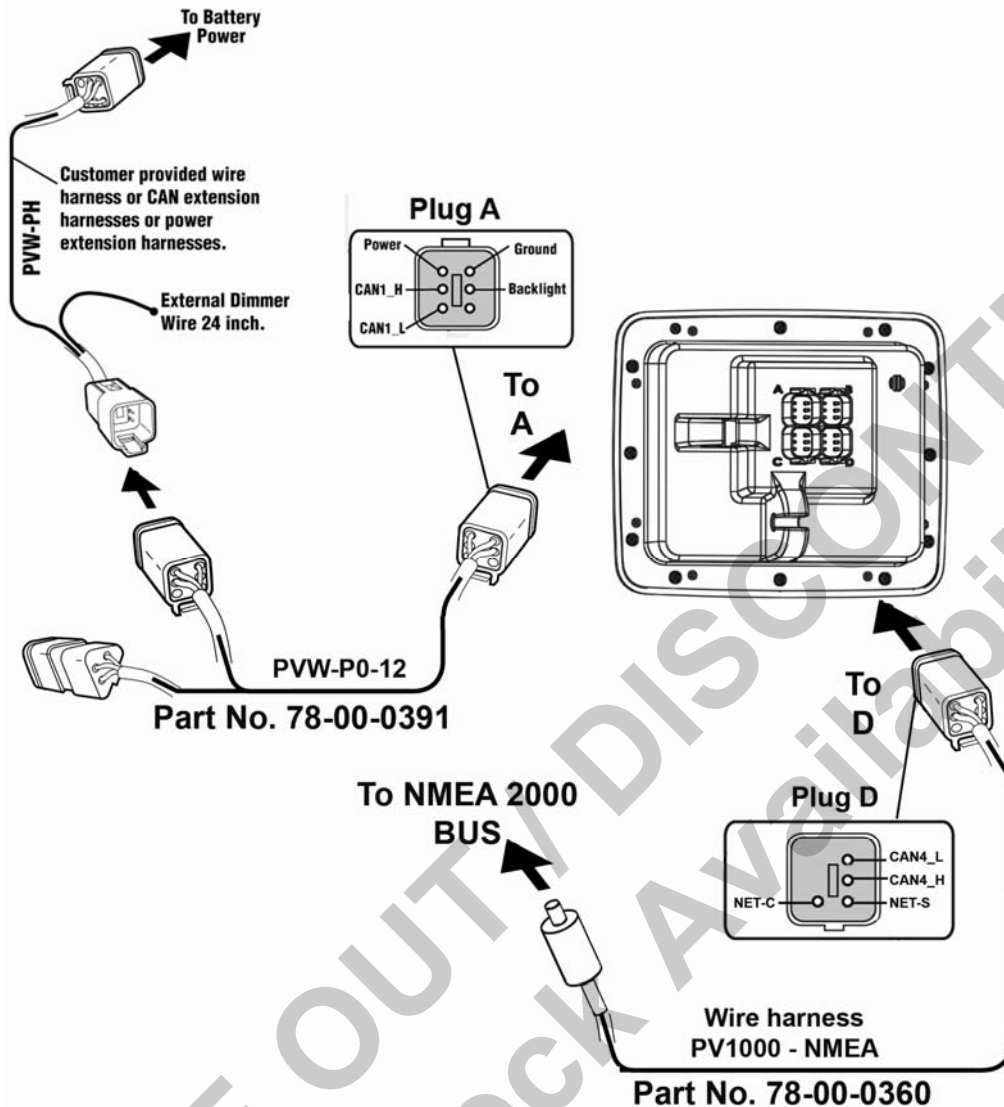

NOTE: The NMEA wire harness contains blocking pins that only allow the cable to be connected to Plug D.

Software Configuration for NMEA Setup

If only NMEA devices such as GPS are connected to Plug D, and engines are connected to Plug A or B, then use the appropriate single or dual engine configuration settings.

NOTE: NMEA can be used in conjunction with all other engine options listed in this manual.

PVA Gages

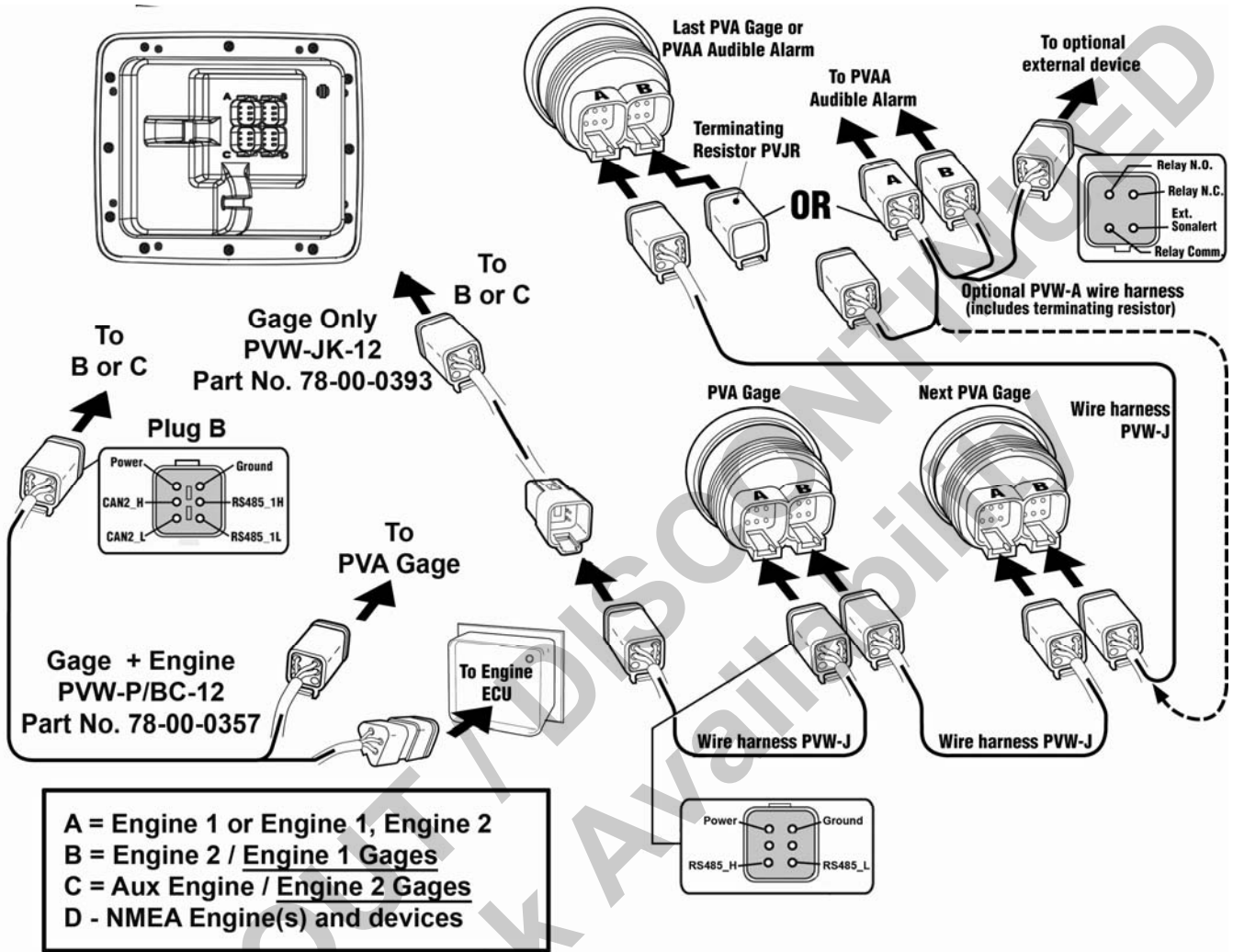

NOTE: Port B and C connectors are keyed differently than Port A and D connectors to ensure proper connection.

Pin Specifications for Deutsch DT04-6P Style Connections

Unit Back View Deutsch DT04-6P Style Connections

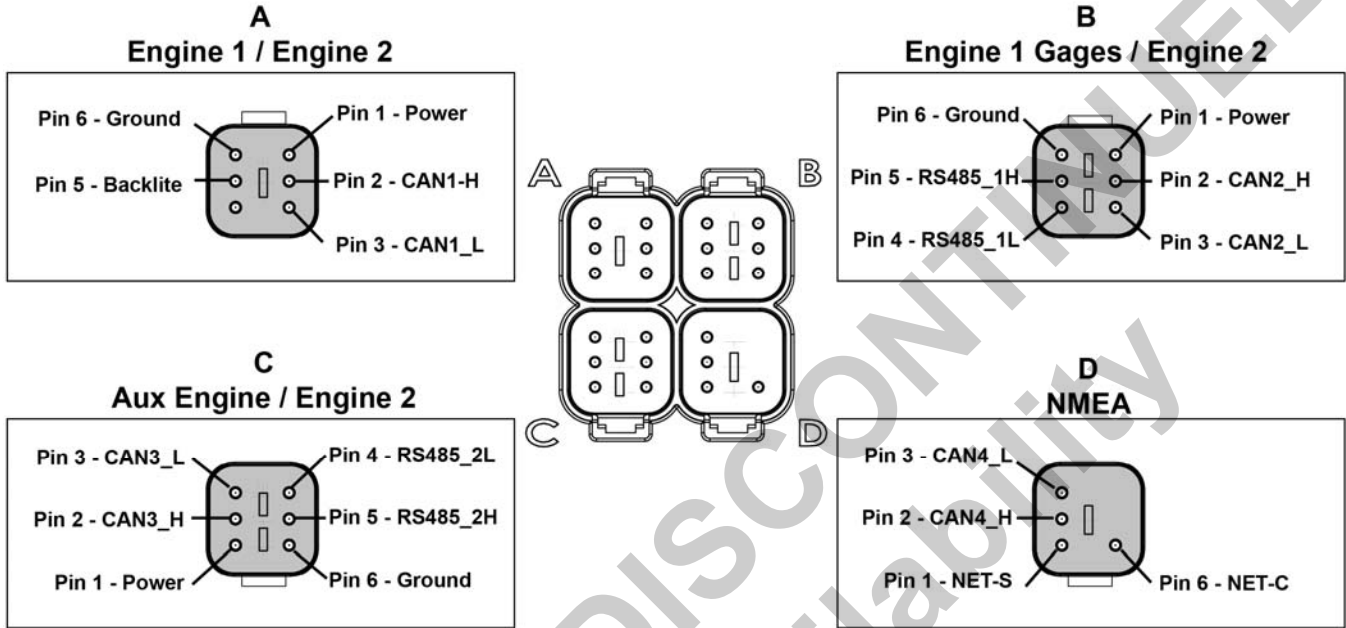

PHASE OUT / DISCONTINUED
Check Availability

Wiring Schematic

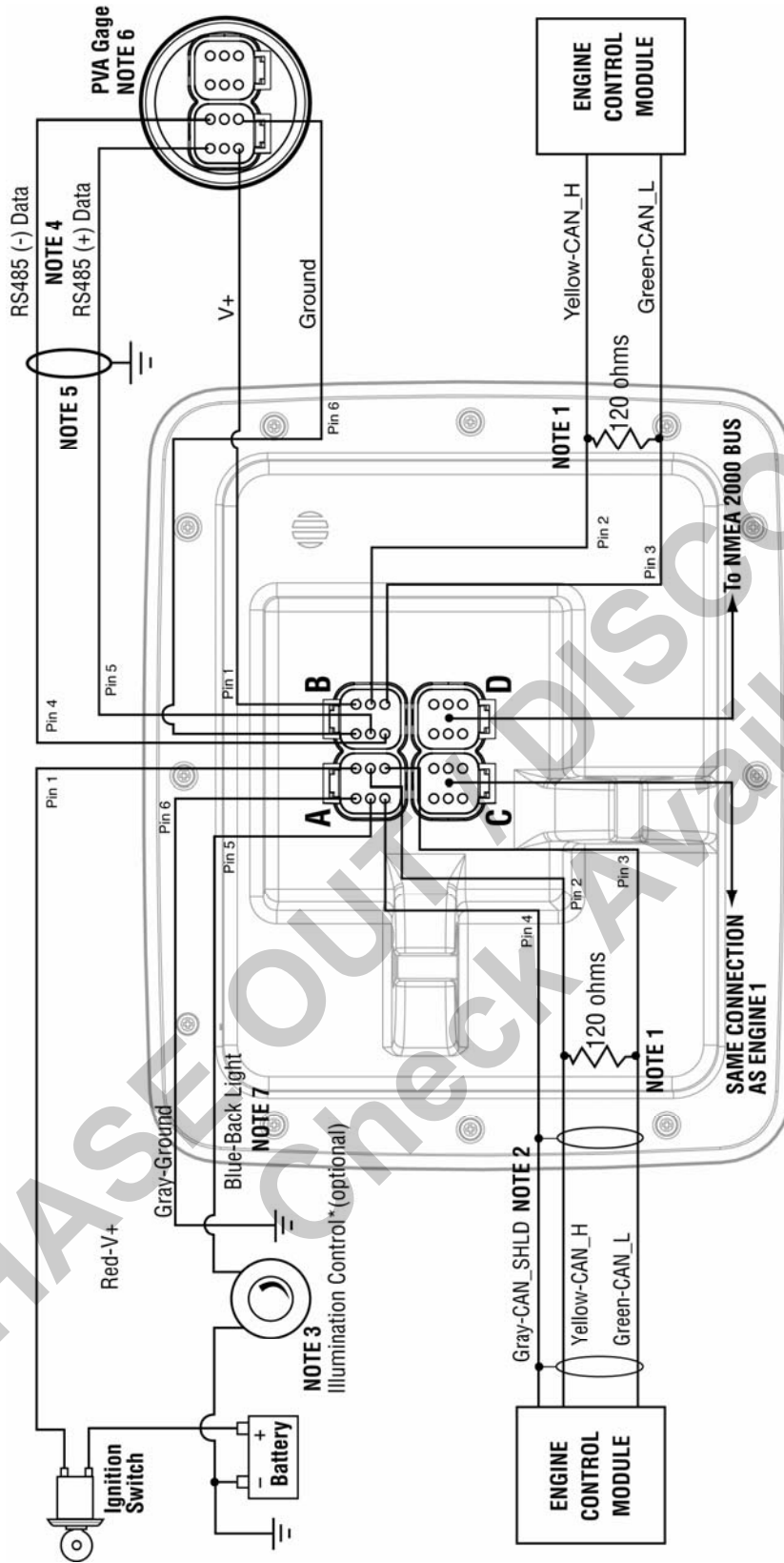

Note 1: Place Resistor between CAN_H and CAN_L Line near PV1000.

Note 2: Use SAE J1939 compliant wiring/equipment.

Note 3: Electronic dimmer switch recommended with 4A, capacity or heavy duty rheostat switch, 1000 ohm, 0.25 watt.

Note 4: Only use 120 ohm characteristic impedance cable, ex Belden 9841.

Note 5: RS485 shield connected to PV1000 end only.

Note 6: Place Resistor at End of Line. (Included for factory purchased panels.)

Note 7: If a backlight dimmer is not used, connect the blue backlight wire to ground. Do not leave the blue backlight wire unconnected.

IMPORTANT: To eliminate external interference: RS485(+) and RS485(-) should be twisted pair cable or twist wires together, one twist per inch minimum. CAN_L, CAN_H and CAN Shield should be approved J1939 CAN bus cable. CAN wire for example: RADOX plug and play cable, from Champlain cable. RS485 wire for example: BELDEN 9841 or 3105A.

Specifications

Electrical

Display	6.4" Color transmissive TFT LCD
Resolution	VGA, 640 x 480 pixels
Orientation	Landscape
Backlighting	CCFL, 350 cd/m ² (50,000 h lifetime) not replaceable
Processor	Sharp ARM9 LH7A404, 200 MHz Philips ARM7 LPC2194 70 MHz
Flash Memory	16 Mbytes
RAM	32 Mbytes SDRAM
EEPROM	32 Kbytes
Operating Voltage	6 to 32 VDC, protected against reverse polarity and load-dump
Power Consumption	10 W full backlight 22 W full backlight with heater (< -10° C)
CAN	4 CAN ports according to CAN specification 2.0B. One port isolated according to NMEA 2000
RS-485	2 MODBUS Master ports at 38.4 Kbaud
Protocols	J1939, NMEA 2000, proprietary
Connection	4 Deutsch DT04-6P 6-pin connectors
Keyboard	8 Capacitive Touch Keys

Mechanical

Mounting Variants	Panel Mounting – Mounts with eight screws into the lip of the bezel. Gimbal Mounting – Uses an articulating gimbal.
Dimensions	(W x H) 8.74 x 7.23 in Panel Mount Depth – 0.605 in Unit Depth – 3.265 in
Cutout for panel mounting	(W x H) 7.15 x 5.65 in
Case Material	High impact acrylic front case Polycarbonate back case
Weight	2 lb

Environmental

Operating Temperature	-40° C to +85° C
Storage Temperature	-40° C to +85° C
Protection	IP68
Emissions	IEC 60945, 95/54/EC
Immunity	SAE J1113, ISO 11452

PHASE OUT / DISCONTINUED
Check Availability

PART # 78-00-0386

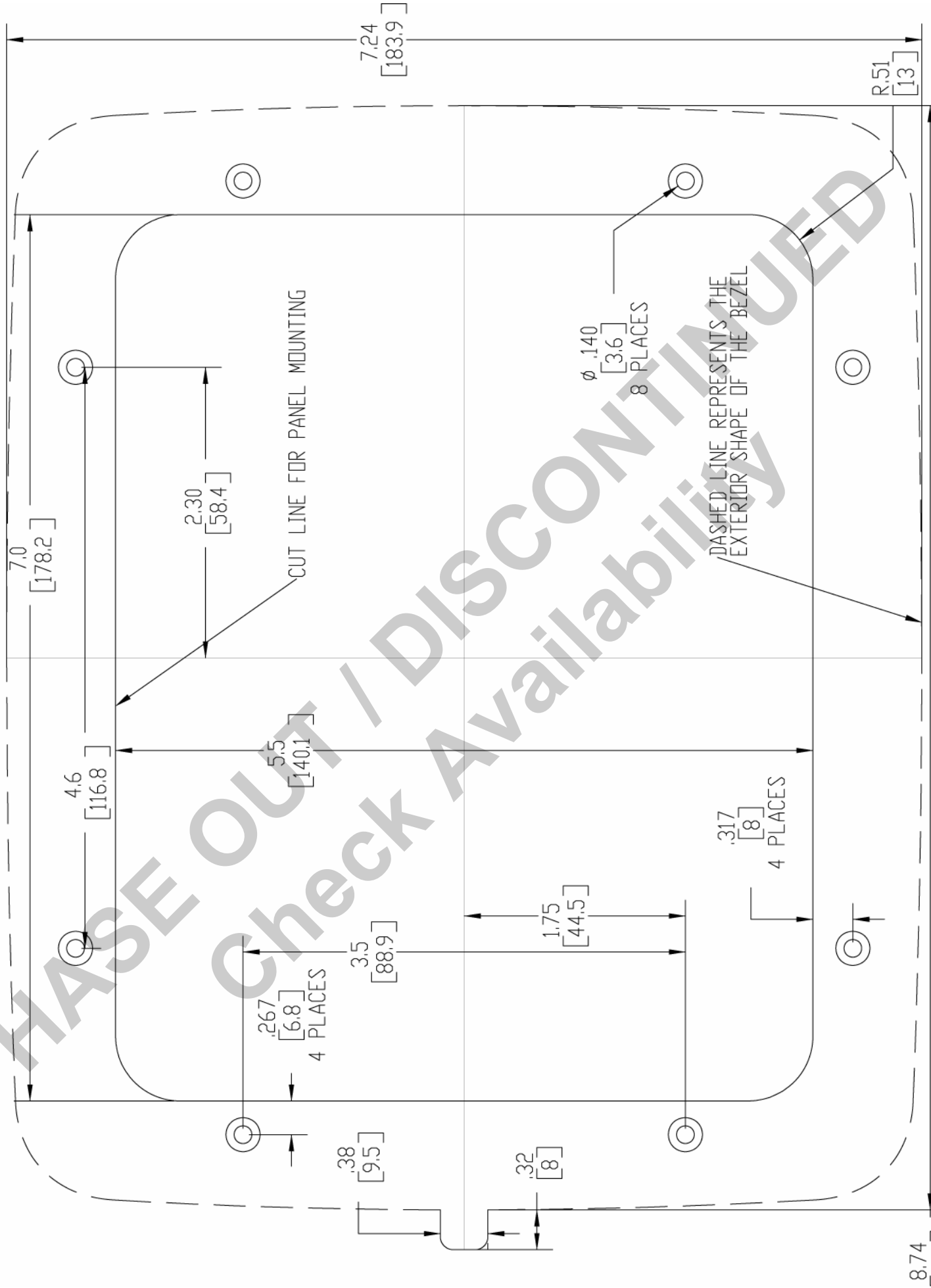

MURPHY, the Murphy logo, PV1000 and PowerView are registered and/or common law trademarks of Murphy Industries, Inc. This document, including textual matter and illustrations, is copyright protected by Murphy Industries, Inc., with all rights reserved. (c) 2006 Murphy Industries, Inc. Other third party product or trade names referenced herein are the property of their respective owners and are used for identification purposes only.

PHASE OUT / DISCONTINUED
Check Availability

PHASE OUT / DISCONTINUED
Check Availability



www.fwmurphy.com
(918) 317-4100 sales@fwmurphy.com