



The  
**PowerView™ 1000**  
display.

This Changes Everything.

P V 1 0 0 0

The New Generation of

# PowerView

FW Murphy's original PowerView 100 display set a new standard for simple-to-read electronic engine monitoring and diagnostics. Now the next generation - the PowerView 1000 display - is here.

We're not raising the standard here. We're rocketing it to a whole new level.



EXPERIENCE EARNED.  
ENGINES UNDERSTOOD.

PHASE OUT / DISCONTINUED  
Check Availability



This Changes

# Everything

What makes the PowerView1000 display  
the highest-quality off-highway tool available?  
In one word: MORE.

More integration. More information. More on-screen action for  
constant engine and equipment monitoring.

How much more do you get? Look inside to see  
everything the PowerView1000 can do.



---

EXPERIENCE EARNED.  
ENGINES UNDERSTOOD.

# PV1000

*For several years, the MurphyLink™ product line has provided  
the leading J1939 instrumentation and monitoring systems.*

*While others are just starting on first-generation products,  
Murphy is several generations ahead.*

*Our first-hand experience gives you higher innovation, stronger reliability  
and a deeper understanding of your electronic engines and equipment.*

PHASE OUT / DISCONTINUED  
Check Availability



### On-Screen Display

What's the first thing you'll notice about the PowerView 1000 display? The huge, full-color VGA flatscreen. The bright, rich graphical detail pops off the screen – even in sunlight. It's a stunning display with pristine graphics and color on the most easy-to-read display.

The extra-large size also gives you extra room for more information. Fit several engine parameters on one screen. Get more detailed diagnostics. Put all your engine and equipment info in one convenient place.

### Integration

You'll need the extra screen space because the PowerView 1000 display is now capable of integrating all major elements of your equipment. With four ports supporting J1939 and NMEA2000 protocols, you can now tie information together from your engine, transmission, equipment, and even GPS into a single interface.

### Customization

Not all off-highway applications need the same engine data. So why give an operator extra info he doesn't need? Configure the PowerView 1000 display graphics to fit your users' needs. Choose from several standard screens to arrange your layout options. You can also work with our Application Engineers to add extra screens for transmission, hydraulic data, and equipment information specifically for your application.

Language shouldn't be a barrier, either. That's why the PowerView 1000 display can be changed from English to Spanish, French, German or Italian through a simple menu setting.

It's your display – let's make it the way you want it.

### Diagnostics and Service Information

The PowerView 1000 display gives diagnostics for the electronic engine's active and stored faults, like the traditional PowerView 101 display. But it also includes regular service reminder screens to tell the operator when to perform scheduled maintenance.

### Trending

Imagine hiring a full-time on-site supervisor to constantly record and report performance data on your equipment. That's the automated trending feature. The PowerView 1000 display no longer just displays data, it archives it for you. Just download it to a standard SD storage card and transfer it to a PC for extra analysis.

### Durability

If it wasn't tough, it wouldn't be Murphy. The PowerView 1000 features a wide storage/operating temperature range, high-impact protective casing in the front and back and IP68 environmental sealing. It's built to bring cutting-edge convenience and technology to the harshest environments. Check the specs and see how solid it is.

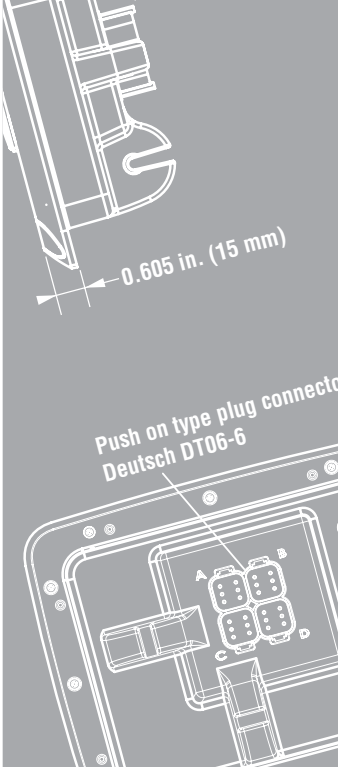

The **PowerView™1000** display.

# Technical Information

- Display: 6.4" Color transmissive TFT LCD
- Resolution: VGA, 640 x 480 pixels
- Orientation: Landscape
- Backlighting: CCFL, 350 cd/mC (50,000 h lifetime)
- Flash Memory: 16 MB
- RAM: 32 Mbytes SDRAM
- EEPROM: 32k bytes
- Operating Voltage: 6-32 VDC, protected against reverse polarity and load-dump
- Power Consumption: 10w full backlight; 22w full backlight with heater (< -10° C)
- CAN: 4 CAN ports according to CAN specification 2.0B; one port isolated according to NMEA 2000 (GPS)
- RS-485: 2 MODBUS Master ports at 38.4 Kbaud
- Protocols: J1939, NMEA 2000 (GPS), proprietary
- Connection: 4 Deutsch DT 6-pin connectors
- Keyboard: 8 capacitive touch keys
- Trending: record and report data; download to a standard SD storage card.

EXPERIENCE EARNED.  
ENGINES UNDERSTOOD.

## MECHANICAL SPECS

- Mounting Variants: Panel mounting – mounts with six screws into the lip of the bezel; Gimble mounting – uses an articulating gimble
- Dimensions (w x h): 8.74" x 7.23" (landscape); Panel mount depth – 0.605"; Unit depth – 3.265"
- Cutout for panel mounting (w x h): 7.15" x 5.65" (landscape)
- Case material: High impact acrylic front case; Polycarbonate back case

## ENVIROMENTAL SPECS

- Operating Temperature: -40° C to +85° C
- Storage Temperature: -40° C to +85° C
- Protection: IP68
- Emissions: IEC 60945, 95/54/EC
- Immunity: SAE J1113, ISO 11452
- Vibration: Random vibration, 7.86Grms(5-2000 Hz), 3 axis
- Shock: +/- 50G in 3 axis

## RKP-PV REMOTE KEYPAD

Remote Keypad allows a user to enter keypad commands whenever display installations are not conveniently located for easy access. Keys allow complete control of PV1000. Audible alarm, Alarm LED's, and temporary silence button built in.



## EXTERNAL DIMENSIONS (Gimble Mounting Shown)



## XM500 I/O MODULE

XM500 I/O module allows you to add more equipment parameters into the display.





### **FW Murphy**

5311 South 122nd East Avenue  
Tulsa, Oklahoma 74146 USA  
Phone: +1 918.317.4100 Fax: +1 918.317.4266  
Email: [sales@fwmurphy.com](mailto:sales@fwmurphy.com)  
Web site: [www.fwmurphy.com](http://www.fwmurphy.com)

### **Frank W. Murphy, LTD.**

Church Rd. Laverstock,  
Salisbury SP1 1QZ U.K.  
Phone: +44.1722.410055 Fax: +44.1722.410088  
Email: [sales@fwmurphy.co.uk](mailto:sales@fwmurphy.co.uk)  
Web site: [www.fwmurphy.co.uk](http://www.fwmurphy.co.uk)

### **FW Murphy Instruments (Hangzhou) Co. LTD.**

77 23rd Street  
Hangzhou Economic & Technological Development Area  
Hangzhou, Zhejiang, 310018, China  
Phone: +86.571.8684.8868 Fax: +86.571.8684.8878

**EXPERIENCE EARNED.  
ENGINES UNDERSTOOD.**

P V 1 0 0 0