

Digital Time Meters



HD35 Series

- Solid-State
- Memory Retention
- Lighted Liquid Crystal Display
- Models for Battery, AC Voltage or CD Ignition Applications

Description

The HD35 Series time meters are low input power, elapsed time meters that record the operating time of vehicles or powered equipment. Timing is by highly accurate and reliable quartz based circuitry. Elapsed time is displayed by a 5-digit Liquid Crystal Display (LCD) which can read up to 9,999.9 hours. The LCD can be powered by either an external battery or DC voltage source. An AC line voltage or a capacitor discharge (CD) ignition can also be used. The elapsed time is maintained by a replaceable 3-year lithium battery when power is removed. The HD35DC provides backlighting of its LCD display. The backlighting is powered by a separate DC power source.

Features

Timer initiation begins when external power is applied to the input terminals and stops when power is removed. The display can be reset to zero through an external switch closure; it is also self zeroing at 9,999.9 hours. A winking display decimal point indicates that the timer is active. The display remains on when power is removed. Memory is maintained by the internal battery.

Specifications

Supply Voltage

- HD35DC: 10-48 VDC or 24 VAC
- HD35CD: 120-250 VAC or CD-Ignition 75-280 VDC

Supply Current

- HD35DC: 50 μ A @ 10 VDC;
3.5 mA @ 40 VDC
- HD35CD: 53 μ A @ 75 VDC;
270 μ A @ 280 VDC

Operating Temperature

-4 to 158°F (-20 to 70°C)

Storage Temperature

-85 to 212°F (-65 to 100°C)

Display Light Supply Voltage

10-48 VDC or 24 VAC

Mounting Hole

3-3/8 in. (86 mm)

Approximate Weight

14 oz. (0.4 kg)

Approximate Dimensions

5-1/2 x 5-1/2 x 5-1/2 in. (140 x 140 x 140 mm)

Warranty

A two-year limited warranty on materials and workmanship is given with this Murphy product. Details are available on request and are packed with each unit.

How to Order

Specify HD35CD or HD35DC.

Dimensions

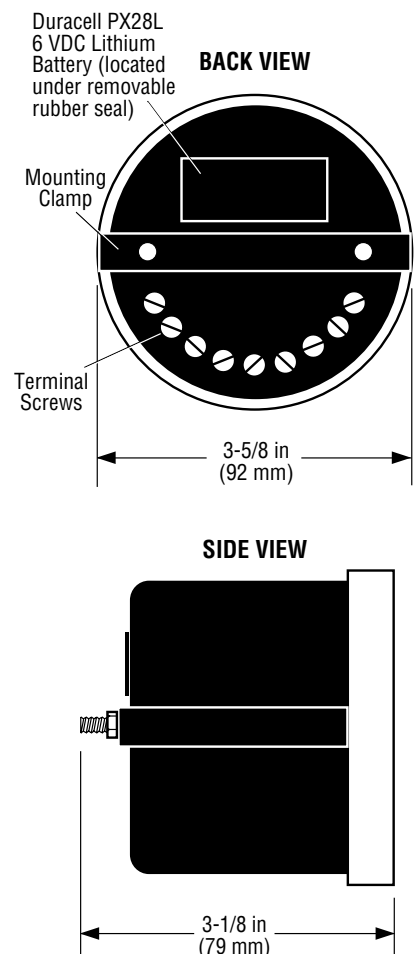

Typical Wiring Diagrams



WARNING: The wiring diagrams below are shown for clarity only.

HD35CD

- 120-250 VAC; CD ignition power.
- Terminals 7 and 8 are connected with a factory installed jumper which initiates a timer immediately after power is applied between terminals 3 and 4.
To initiate the timer by a remote switch remove the factory installed jumper between 7 and 8.
- Connecting terminals 5 and 6 resets the timer to zero.
- Connect terminal 3 to positive ignition lead.
Connect terminal 4 to negative ignition lead.
- When replacing battery use only Duracell PX28L 6 VDC Lithium battery. **CAUTION:** Unless external power is applied on terminals 3 and 4, timer will zero when battery is removed.

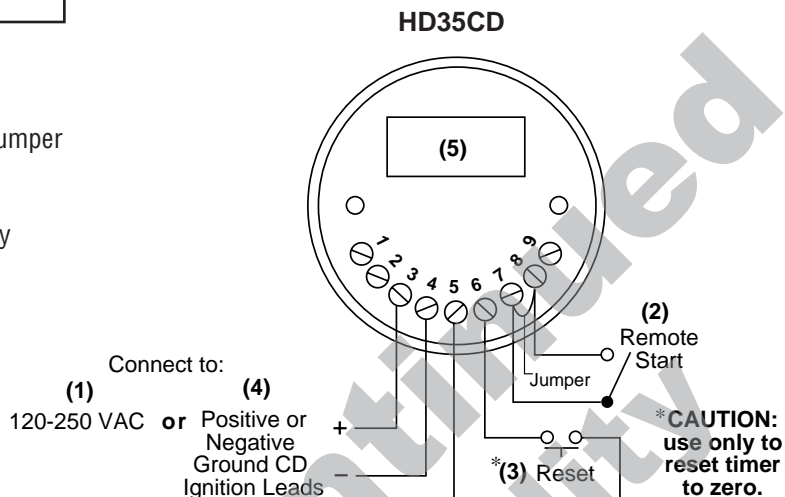

HD35DC

- 10-40 VDC/24 VAC input.
- Terminals 7 and 8 are connected with a factory installed jumper which initiates a timer immediately after power is applied between terminals 3 and 4.
To initiate the timer by a remote switch remove the factory installed jumper between 7 and 8.
- Connecting terminals 5 and 6 resets the timer to zero.
- Connect terminal 3 to power positive.
Connect terminal 4 to power negative.
- When replacing battery use only Duracell PX28L 6 VDC Lithium Battery. **CAUTION:** Unless external power is supplied on terminals 3 and 4, timer will zero when battery is removed.
- Display lighting requires 10-40 VDC/24 VAC.

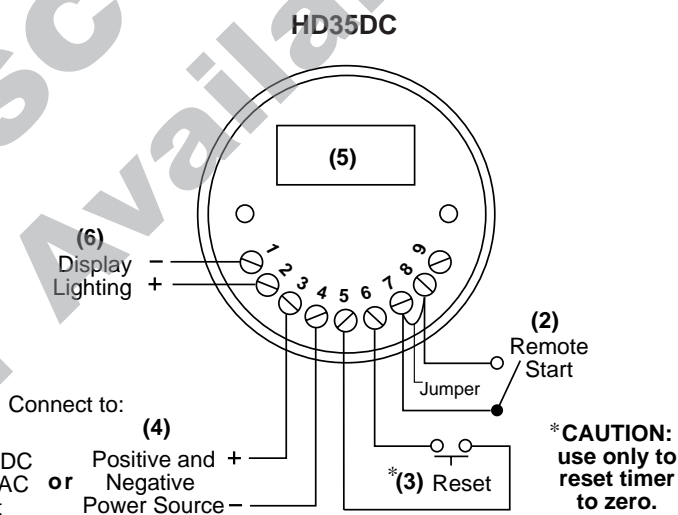

In order to consistently bring you the highest quality, full featured products, we reserve the right to change our specifications and designs at any time.



■ **Frank W. Murphy Manufacturer**
P.O. Box 470248; Tulsa, Oklahoma 74147; USA
tel. (918) 627-3550 fax (918) 664-6146
e-mail sales@fwmurphy.com

■ **Frank W. Murphy Southern Division**
P.O. Box 1819; Rosenberg, Texas 77471; USA
tel. (281) 342-0297 fax (281) 341-6006
e-mail murphysd@intertex.net

■ **Frank W. Murphy, Ltd.**
Church Rd.; Laverstock, Salisbury SP1 1QZ; U.K.
tel. +44 1722 410055 fax +44 1722 410088 tlx 477088
e-mail sales@fwmurphy.co.uk

■ **Frank W. Murphy Pte., Ltd.**
No. 2 Tuas South Street 2, Sprintecs Bldg., #02-01/02
Singapore 638042
tel. +65 863-1398 fax +65 863-0208
e-mail fwmsales@fwmurphy.com.sg

■ **Murphek Pty., Ltd.**
1620 Hume Highway; Campbellfield, Vic 3061; Australia
tel. +61 3 9358-5555 fax +61 3 9358-5558
e-mail murphy@macquarrie.com.au

■ **Murphy de México, S.A. de C.V.**
Blvd. Antonio Rocha Cordero 300, Fracción del Aguaje
San Luis Potosí, S.L.P.; México 78384
tel. +52-48-206264 fax +52-48-206336
e-mail murmexsl@sanluis.podernet.com.mx

■ **Murphy Switch of California**
P.O. Box 900788; Palmdale, California 93590; USA
tel. (805) 272-4700 fax (805) 947-7570
e-mail sales@murphyswitch.com

■ **Frank W. Murphy France**
tel. +33 1 30 762626 fax +33 1 30 763989