

Tattletale® Digital Fault Annunciator Installation and Operation Instructions

MRK-92133N
Revised 08-06
Section 50
(00-02-0223)

Models: MARK II-P, MARK II-N; MARK IV-N, MARK IV-12/24



Please read the following information before installing. A visual inspection for any damage which may have occurred during shipping is recommended. This installation manual is intended for all MARK II Series and MARK IV Series models.

GENERAL INFORMATION

WARNING

BEFORE BEGINNING INSTALLATION OF THIS MURPHY PRODUCT

- ✓ Disconnect all electrical power to the machine.
- ✓ Make sure the machine cannot operate during installation.
- ✓ Follow all safety warnings of the machine manufacturer.
- ✓ Read and follow all installation instructions.

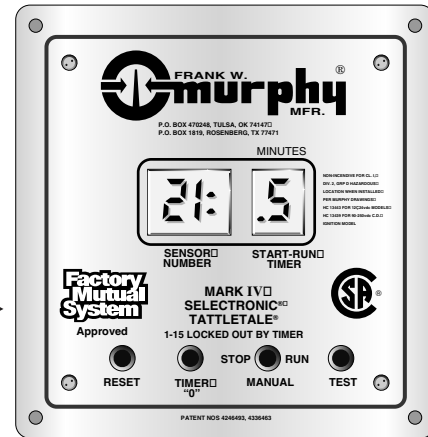

Description

The MARK II and MARK IV are solid-state fault annunciators and shutdown control systems, designed to protect engines and associated equipment. A power supply is built into the unit and models are available which are powered from either positive or negative ground CD ignitions or from 12/24 VDC. Signal inputs are supplied from normally open sensors such as Murphy Switchgag® instruments. A Liquid Crystal Display (LCD) annunciates any fault from input sensors. A 5-minute start-run timer is displayed during start-up. A test mode is provided to test the sensor circuits without shutting down the equipment.

On-board backup battery retains the fault display after engine shutdown. These annunciators provide for both, closing of a fuel valve and grounding the ignition for shutdown. It is recommended to use a 2 to 3 second time delay in grounding the ignition after the fuel valve closes (see page 2). Models available:

MARK II-P: monitors 24 sensor inputs; for positive ground CD ignitions.

MARK II-N: monitors 24 sensor inputs; for negative ground CD ignitions.

MARK IV-N: monitors 47 sensor inputs; for negative ground CD ignitions.

MARK IV-12/24: monitors 47 sensor inputs; for 12 or 24 VDC.

Specifications

Power: CD ignition (90-250 VDC); 12 or 24 VDC.

NOTE: Module cannot be powered by a magneto ignition.

Power Consumption: 450 μ A, 100 VDC.

Power Inputs (Operating Voltages):

MARK II-P: 90-250 VDC, CD ignition, positive ground.

MARK II-N and MARK IV-N: 90-250 VDC, CD ignition, negative ground.

MARK IV-12/24: 12-24 VDC 0.7 VA maximum (4.7 watts with 2 customer-supplied, typical hermetically sealed relays).

Sensor Inputs: MARK II accepts 24 sensor switches.

MARK IV accepts 47 sensor switches. Sensor switches must be grounding contacts such as Murphy SWITCHGAGE® instruments.

Outputs: MARK II-N, MARK IV-N and MARK IV-12/24: F.E.T. (Field Effect Transistor) rated at 0.5 A, 250 V maximum.

**Suitable for Class I, Division 2,
Hazardous Locations**

WARNING: We do not recommend the use of switches having contacts immersed in oil. Because the MARK II and the MARK IV operate on low voltage, the oil may act as an insulator between the contacts. When using the MARK IV-12/24 with inductive loads, we recommend installing a suppression diode across all coils.

MARK II-P: S.C.R. (Silicon Controlled Rectifier) rated at 0.5 A, 250 V maximum.

Operating Temperature: -4 to 158°F (-20 to 70°C).

Storage Temperature: -40 to 302°F (-40 to 150°C).

Case: Anodized aluminum.

Multiplexer Scan Rate: MARK II: Scans all 24 sensors in 0.5 seconds.

MARK IV: Scans all 47 sensors in 0.5 seconds.

Start-Run/Test Time: 5 minutes standard.

Laboratory Approvals:

CSA* and FM approved for Class I, Division 2, hazardous areas.

CSA approved for Groups C and D; FM approved for Group D.

Backup Power:

MARK II: On-board 6 VDC @ 160 mAh, PX28L lithium battery.

MARK IV: On-board 6 VDC @ 1300 mAh, DL223A lithium battery.

Shutdown Outputs: Positive ground version: SCR; 0.5 amp @ 250 V max.

Negative ground and 12/24 VDC versions: FET; 0.5 amp @ 250 V max.

Output Selections: • Ground Ignition immediately.

• Trip fuel valve, then ground ignition after a delay of 2-3 seconds. (Time delay is factory set, but field selectable, see page 2.)

NOTE: MARK IV-12/24 outputs turn off for shutdown.

Sensor Terminal Block: Plug-in terminal(s) with screw type connections.

*Rated 90-250 V, CD ignition or 12-24 VDC/4.7 watts and non-incendive field wiring connections as per drawing HC 13439 and HC13443.

MOUNTING DIMENSIONS



The module is designed to be mounted within a weatherproof enclosure. A 5-1/2 in. (140 mm) square hole, and four 3/16 in. (5 mm) dia. screw holes are needed (see drawing below). Insert the unit from the front side of the enclosure and secure it with mounting screws.

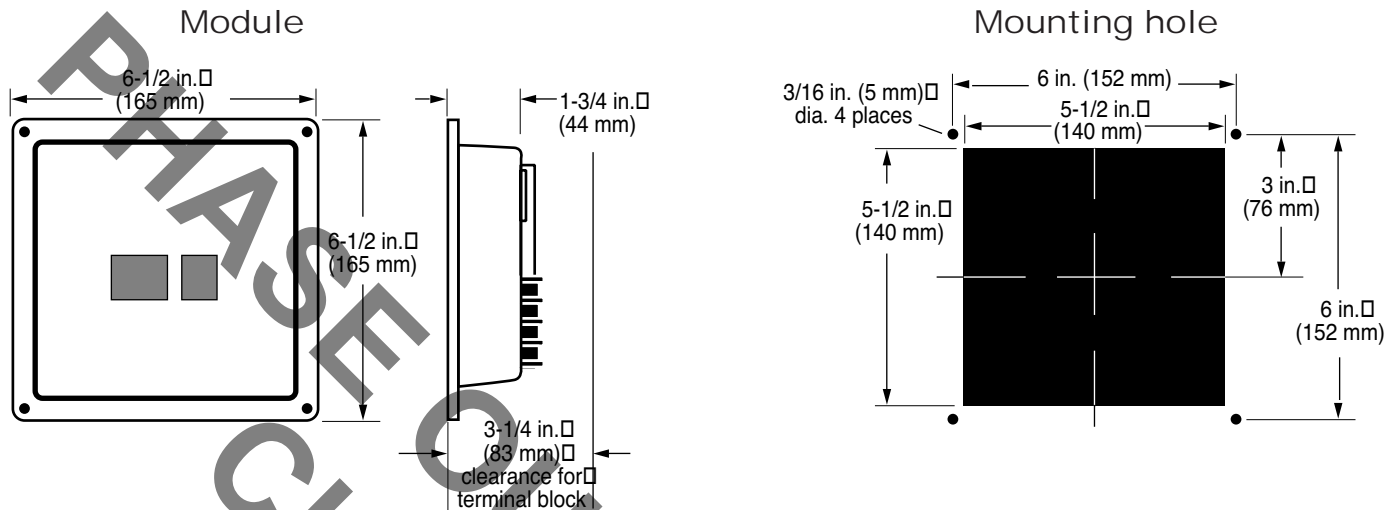

TYPICAL WIRING INSTALLATION



WARNING: For Hazardous application requirements, the MARK II and IV Series models must be installed in accordance with the National Electrical Code (NEC) Cl. I, Div. 2, Gps. C & D specifications, and per Murphy drawings HC12581, HC12580, HC13503, HC13439, HC13443. Route sensor leads in conduit separate from ALL other wire. Do NOT apply voltage to any annunciator input terminals. When using the MARK IV-12/24 with inductive loads, we recommend installing a suppression diode across all coils.

Time Delay for Ignition Grounding

To obtain the ignition ground delay a jumper must be removed from the module. Locate the backup battery cover on back of the module. On the MARK II series remove the jumper between eyelets E1 and E2 (see drawing below). For MARK IV series, remove jumper E2.

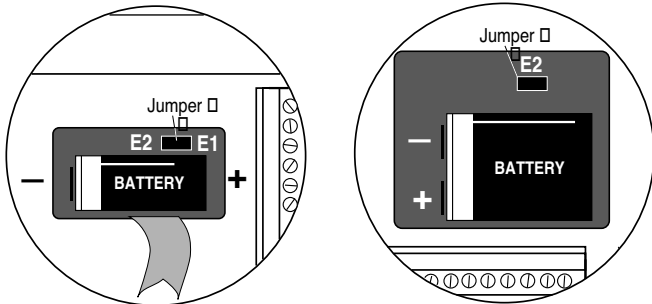

MARK II Series

MARK IV Series

Customer Wiring Installation

Locate user terminal block (back side of the module).

Model MARK II-P (See MARK II-P wiring diagram, page 3.)

1. Run wiring from ignition or fuel valve to the monitor through conduit. Connect ignition lead to IGN-1 on the power terminal block.
2. Connect fuel valve lead to terminal F/V.

Models MARK II-N and MARK IV-N (See MARK II-N wiring diagram on page 3, or MARK IV-N wiring diagram on page 4.)

1. Run wiring from ignition or fuel valve to the unit through conduit. Connect ignition lead to IGN-1 on the power terminal block.
2. Connect fuel valve leads between MARK II module terminal F.V. and IGN-1.

Models MARK IV-12/24 (See wiring diagram on page 4.)

1. Connect the 12/24 terminal to the 12-24 VDC power source, which can be engine battery or alternator. (For alternator-only applications contact Murphy.)
 2. Connect GRD (ground) terminal to 12-24 V ground.
- NOTE:** The S/D (shutdown) and F/V (fuel valve) terminals will sink to ground when the unit is in the run condition. When a shutdown occurs these terminals will go open circuit.
3. Connect the relays as needed. Connect relay coil negative to the S/D or F/V terminals. The 12/24 V relay uses a spike suppression diode across the coil.
- CAUTION:** Not having a diode will result in a damaged unit. To meet the hazardous locations requirements, relays "K1" and "K2" must be hermetically sealed.
4. The positive side of the 12-24 V relay should be connected to the 12-24 VDC power source.

NOTE: Normally open contacts of the relay will be closed as long as the annunciator is in run condition (open on shutdown).

Class A and B sensor input wiring for all MARK II Models

1. Sensors not locked out during start up are wired to terminals 1 thru 15. (Terminal 15 is dedicated for manual stop, terminal 14 is for electronic digital speed switches.)
2. Sensors locked out during start up are wired to terminal 16 thru 24.

Class A and B sensor input wiring for all MARK IV Models

1. Sensors locked out during start up are wired to terminals 1 thru 15.
2. Sensors locked out during start up are wired to terminal 16 thru terminal 47. (Terminal 47 is dedicated for manual stop, terminal 46 is for electronic digital speed switches.)

TYPICAL WIRING INSTALLATION *continued*



WARNING: For Hazardous application requirements, the MARK II and IV Series models must be installed in accordance with the National Electrical Code (NEC) Class I, Div. 2, Gp. D specifications, and per Murphy drawings HC12581, HC12580, HC13503, HC13439, HC13443. Route sensor leads in conduit separate from ALL other wire. Do NOT apply voltage to any annunciator input terminals.

MARK II-P Wiring

(For use in Class I, Div. 2 Gp. D Hazardous Locations)

Sensor leads maximum length= 200 ft.

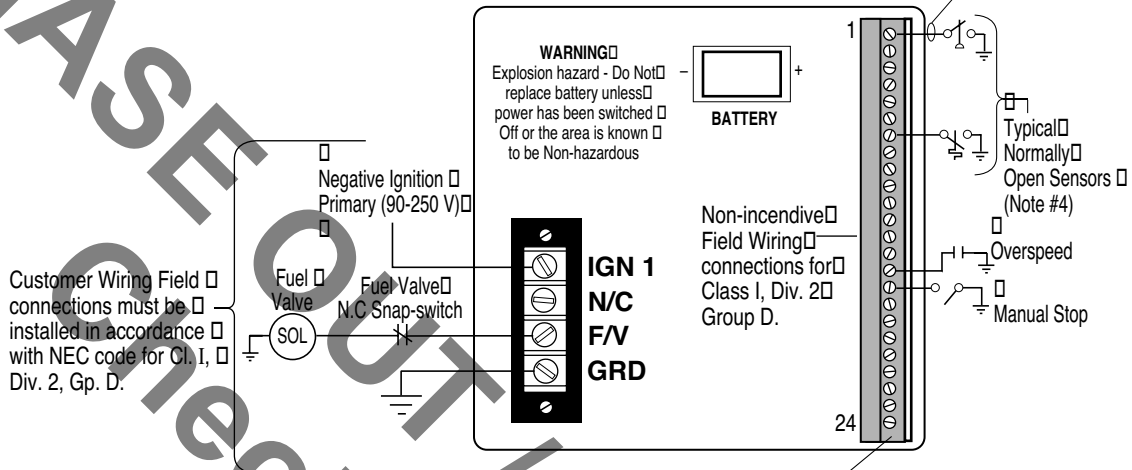

NOTES:

1. Sensor inputs 16-24 are timed for start-up.
2. Sensor number 15 is manual stop (internal).
3. Terminal 14 is dedicated for electronic digital speed switches with SCR output.
4. Sensors are normally open, mechanically actuated passive switches return to ground potential to activate annunciator.
5. Polarity of the sensor leads is positive with respect to ground.
6. Non-incandive field circuits—VOC= 10.5 VDC, ISC= 1.2 mA., CA= 21 μ f, LA= 1000 mH.

□ Sensor Switch input terminal strip, negative to ground (route sensor leads in conduit separated from all other wiring). Non-incandive field wiring connections for Class I, Div. 2, Group D.

MARK II-N Wiring

(For use in Class I, Div. 2 Gp. D Hazardous Locations)

Sensor leads maximum length= 200 ft.

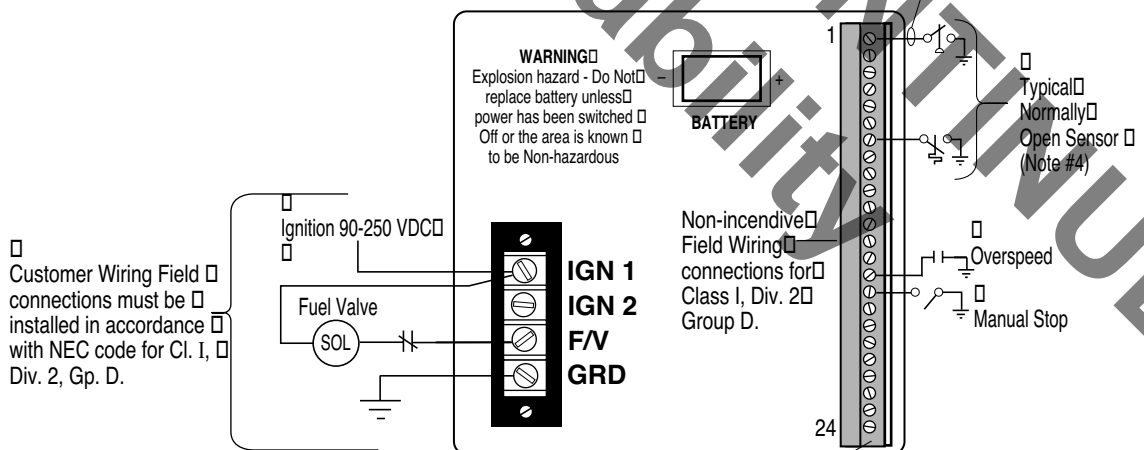

NOTES:

1. Sensor inputs 16-24 are timed for start-up.
2. Sensor number 15 is manual stop (internal).
3. Terminal 14 is dedicated for electronic digital speed switches with SCR output.
4. Sensors are normally open, mechanically actuated passive switches return to ground potential to activate annunciator.
5. Non-incandive field circuits—VOC= 10.5 VDC, ISC= 1.2 mA., CA= 21 μ f, LA= 1000 mH.
6. For use with negative ground.

□ Sensor Switch input terminal strip (route sensor leads in conduit separated from all other wiring). Non-incandive field wiring connections for Class I, Div. 2, Group D.

TYPICAL WIRING INSTALLATION *continued*



WARNING: For Hazardous application requirements, the MARK II and IV Series models must be installed in accordance with the National Electrical Code (NEC) Cl. I, Div. 2, Gps. C & D specifications, and per Murphy drawings HC12581, HC12580, HC13503, HC13439, HC13443. Route sensor leads in conduit separate from ALL other wire. Do NOT apply voltage to any annunciator input terminals. When using the MARK IV-12/24 with inductive loads, we recommend installing a suppression diode across all coils.

MARK IV-N Wiring

(For use in Class I, Div. 2 Gps. C & D Hazardous Locations)

Customer Wiring Field connections must be installed in accordance with NEC code for Cl. I, Div. 2, Gp. D.

NOTES:

1. Sensor inputs 1-15 are timed for start-up.
2. Sensor 15 also connected to internal Ignition Voltage Monitor
3. Sensor number 47 is manual stop (internal).
4. Sensor number 46 is dedicated for electronic digital speed switches with SCR output.
5. Sensors are normally open, mechanically actuated passive switches. Returned to ground potential to activate annunciator.
6. IGN 1 closes to ground on shutdown, and is open from normal. FV-closes to ground from shutdown, and is open for normal. Peak ignition energy is stored and available to trip the fuel valve on terminal FV+.
7. Non-incendive field circuits-VOC= 10.5 VDC, ISC= 1.2 mA, CA= 21 μ f, LA= 1000 mH.
8. Typical wiring installation for use with negative ground.

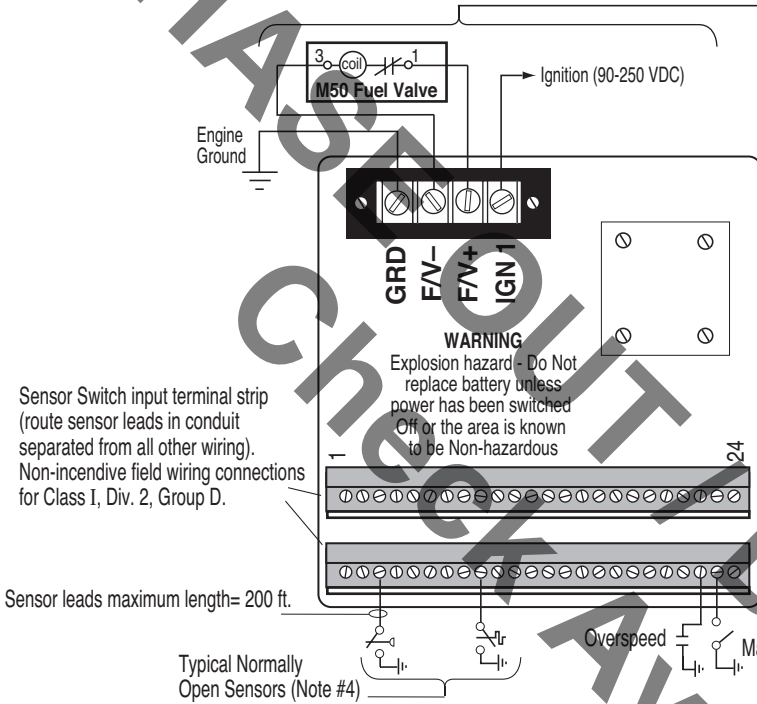

MARK IV-12/24 Wiring

(For use in Class I, Div. 2 Gps. C & D Hazardous Locations)

Customer Wiring Field connections must be installed in accordance with NEC code for Cl. I, Div. 2, Gp. D.

NOTES:

1. Sensor inputs 1-15 are timed for start-up.
2. Sensor number 47 is manual stop (internal).
3. Sensor number 46 is dedicated for electronic digital speed switches with SCR output.
4. Sensors are normally open, mechanically actuated passive switches. Returned to ground potential to activate annunciator.
5. Relays are energized for run, relays are de-energized to stop.
6. Non-incendive field circuits-VOC= 10.5 VDC, ISC= 1.2 mA, CA= 21 μ f, LA= 1000 mH.

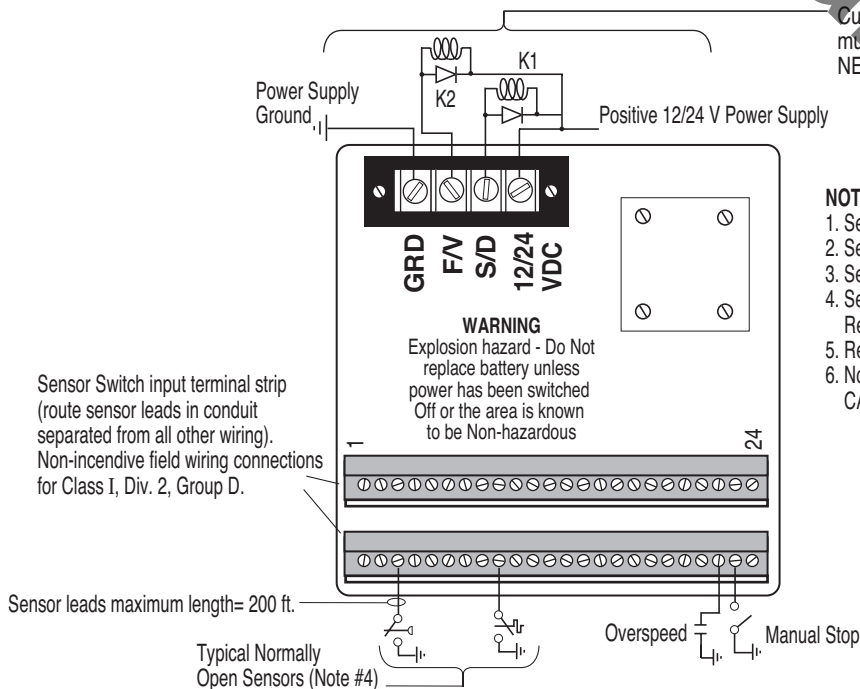

CONTROLS AND INDICATORS DESCRIPTION

The **Module** is a multiplexed data selector with input for sensor channels (24 inputs for MARK II and 47 inputs for MARK IV). MARK II's channel 15 is designated for manual stop. The MARK IV's channel 47 is used for manual stop. A tripped sensor appears as a Logic-0 to the multiplexer at the associated input. The multiplexer sequentially addresses the input channels, once each 0.5 seconds for MARK II models, and once each 0.75 seconds for MARK IV models. A tripped sensor (or a Panel STOP) is detected within 0.75 seconds after being tripped.

Power and Control Inputs/Outputs are interconnected from the power source and loads to the module through a 4-point terminal block, on back of the module.

Liquid Crystal Display (LCD) displays the appropriate sensor number in the left two digits; lockout timer countdown (in minutes) is displayed in the right window. A colon (:) in left display window indicates TEST mode. For MARK II models, a single dot in the right window, with TEST button depressed indicates battery condition, for MARK IV models, no dot indicates low battery.

Sensor Terminal Functions (MARK II models)

- 1–15 for monitoring operating parameters. (Class "A" functions, not locked out by the start/run timer.)
- 16–24 for monitoring parameters that are faulted while engine is not running. (Class "B" functions locked out by start/run timer.)
- 14 for monitoring overspeed. 15 for monitoring manual shutdown. (Upon a STOP, Sensor 15 is indicated in the LCD.)

Sensor Terminal Functions (MARK IV models)

- 16–47 for monitoring operating parameters. (Class "A" functions, not locked out by the start/run timer.)
- 1–15 for monitoring parameters that are faulted while engine is not running. (Class "B" functions locked out by start/run timer.)
- 46 for monitoring overspeed.
- 47 for monitoring manual shutdown. (47 is indicated in the display.)

Manual Stop/ Run Switch shuts down the system from the panel by simulating a fault condition on sensor input. The sensor number for manual shutdown will be displayed. For normal operation, the switch must be placed in RUN.

Reset Push-button resets all tripped sensor inputs and the display. Also resets Start-Run Timer to full count. If any non-locked out sensor is operated, its number will be displayed when RESET is pressed. It also resets alarm or shutdown outputs.

Timer "0" Push-button zeroes the Start-Run Timer as indicated by "0" in Timer window. If in the START mode, pressing the button ends start-up, initiating RUN mode, (if in TEST, it ends the test).

Test Push-button: After start-up the TEST button sets the unit in the test mode. In TEST the unit displays sensor fault inputs as in normal operation (but system is not shut down by sensor operation). Also the TEST period is timed and the system automatically is out of TEST when time expires. During TEST a colon (:) is displayed on the right side of sensor number window.

Tripped Sensors: When a tripped sensor is detected, the signal is transferred by the multiplexer to the module. The sensor number is displayed and a control signal is sent to shut down the engine. The sensor number is retained in the display. The remaining sensor inputs are disabled until the unit is manually reset.

Start-Run Timer: Allows five (5) minutes for the system to come up to speed without a shutdown by speed related conditions (such as low oil pressure). Time is indicated in the Start-Run Timer window. As the time period is used up, the timer counts down to zero. At start-up, Class "B" sensor inputs are locked out until the time expires. The system should be up to speed and the locked out parameters should be normal. If any of the sensors are still tripped at the end of the time period, the engine is shutdown and the faulted sensor displayed. Pressing the Timer "0" push button forces the time count to zero, ending the start-up lockout period.

Start-Run Timer as Test Timer: In the TEST mode, the Start-Run timer locks all the shutdown functions. All sensors can be tested. The timer also allows all sensors to be tripped and displayed, but inhibits shutdown due to tripped sensors until time zero. The RESET and TEST buttons set the unit into the TEST mode for the Start-Run timer period. It is shown as a colon (:) in the Sensor Number window. Press Reset button and the timer restarts a full count.

Time Delay for Ignition Grounding: A three second time delay will be allowed in grounding the ignition after the fuel valve closes. Remove jumper E1/E2 for MARK II models. Remove shunt jumper E2 for MARK IV models. (See page 2.)

Ignition Voltage Monitoring and Annunciation (MARK IV Models only): This is an internal function that monitors low ignition voltage or ignition failure. When ignition voltage drops below 35 VDC approximately, the sensor number 15 is displayed on the sensor window. Input 15 may also be used as a sensor switch input.

SEQUENCE OF OPERATIONS

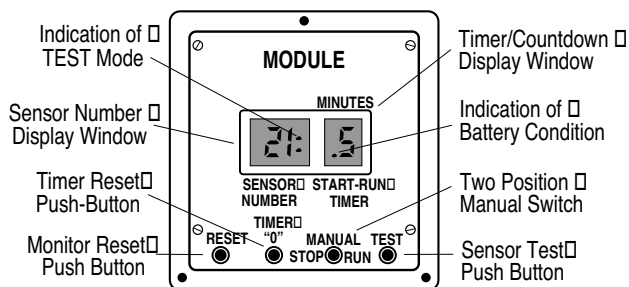

Perform this operation with the unit properly installed and sensors cleared.

Initially Faulted Sensor Check (before start-up).

1. Set Manual Stop-Run Switch to RUN, then press RESET and observe Sensor Number window for faulted sensor indication.
2. Clear any faulted sensors (if necessary).

System Start-up

1. Set Manual Stop-Run Switch to RUN.
2. Press RESET to clear any annunciated sensors and unground or enable the ignition for engine operation.
3. Apply starting power to engine. At time out of the Start-Run Timer, all locked out sensors are set into service.

NOTE: If engine fails to start, refer to Troubleshooting section, page 6.

Sensor Test

This test will verify that sensors are hooked up and working.

1. Press RESET to override shutdown function while sensors are being tested and to reset timer.
 2. Press TEST push button and verify that the colon is in the display to indicate TEST mode, and that full count appears in Start-Run Timer display.
- NOTE:** Test ends automatically when the timer time expires; however, full time is reset each time RESET is depressed.
3. Trip first sensor to be tested and verify that sensor number appears in Sensor Number window.
 4. Clear sensor just tripped then press the reset push button and verify that sensor number is cleared from Sensor Number and that full count appears on LCD window.
- NOTE:** If you fail to clear the unit after tripping a sensor, the engine will shut down when the timer time expires.
5. Repeat Steps 1 and 2 for each sensor.
 6. To end test, press Timer "0" push button.

System Shutdown

Set the Manual STOP/RUN switch to STOP. Verify that the engine stops and that the manual stop number is displayed.

TROUBLESHOOTING INSTRUCTIONS



WARNING: Do NOT apply voltage to input terminals. Do NOT bundle sensor wires with other wiring. Make sure that panel ground and device ground are the same, and are well connected. Make sure that the ground from the unit being monitored is connected directly to the ignition. Make sure suppression diodes are installed across all coils when using the MARK IV-12/24 with inductive loads.

The following checks will assist in the correction of most problems which you may encounter with the unit. Before going through the check list below, first refer to the connections and operation procedures.

If any problems persist after you have made these checks, consult your nearest Murphy facility.

Symptom: No display

1. Check that the backup battery is in place and properly installed (see Backup Battery Replacement, below).
2. Check battery voltage. MARK II series requires a Duracell PX28L lithium battery, 6 VDC. MARK IV series requires a Duracell DL223L lithium battery, 6 VDC. Measure the battery voltage while it is mounted in the module. Voltage must be between 4.8 and 6 VDC.

NOTE: If after completing these three checks, and there is still no display, return the complete unit to Murphy.

Symptom: Random shutdowns, or shutdowns that are announced but not connected.

1. Unplug the terminal strip(s) from the back of the module, and press the RESET push-button. The power cables should be connected, and the backup battery should have already been checked. If no shutdowns are displayed with the terminal strip(s) disconnected, then the module is operating correctly.
2. Check that the power leads and the sensor input leads are separated from each other by a minimum of 6 in. (152 mm)

NOTE: If shutdown still results, send the unit back to us.

Symptom: Engine fails to start (fails to unground ignition).

1. Turn the Stop-Run switch to stop. Press the Reset button and release. Verify that manual shutdown sensor number is displayed.
2. Turn the Stop-Run switch to run position, then momentarily press the Reset button to clear the display. This should unground the ignition and allow the engine to start.

BACKUP BATTERY REPLACEMENT

Battery Check

Hold down TEST push button and check Start-Run Timer display. For MARK II series models, a decimal point in the display indicates low battery (see drawing right). For MARK IV series models, NO decimal point indicates low battery.

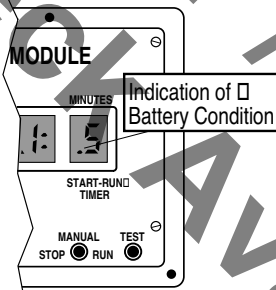

Replacing the Battery

1. Remove the cover located on the back of the module (MARK II series has a black rubber plug; MARK IV series has an aluminum plate). Remove the battery. (See reference drawings right.)
2. Check for the correct polarity, then replace the battery.
3. Replace the cover. Make sure that none of the wiring leads of the terminal block have been accidentally removed.

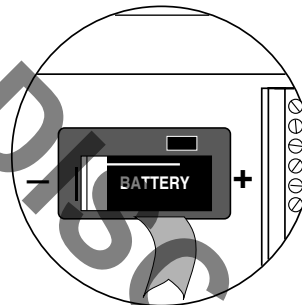

MARK II Series requires a PX28L, 6 VDC, lithium battery

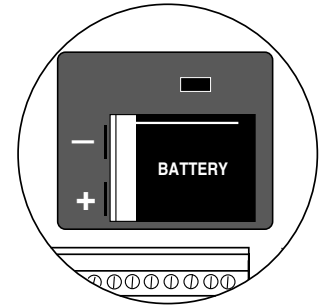

MARK IV Series requires a DL223L, 6 VDC, lithium battery

Warranty

A limited warranty on materials and workmanship is given with this FW Murphy product. A copy of the warranty may be viewed or printed by going to www.fwmurphy.com/support/warranty.htm

MURPHY
www.fwmurphy.com

918.317.4100 Email: sales@fwmurphy.com

MURPHY, the Murphy logo, and Tattletale® are registered and/or common law trademarks of Murphy Industries, Inc. This document, including textual matter and illustrations, is copyright protected by Murphy Industries, Inc., with all rights reserved. (c) 2006 Murphy Industries, Inc. Other third party product or trade names referenced herein are the property of their respective owners and are used for identification purposes only.