

TTDJ Series Fully Configurable Fault Annunciator Installation and Operations Manual

TTDJ-99062N
Revised 2014-08-08
Section 50
(00-02-0412)



Please read the following information before installing. This installation information is intended for all TTDJ Series models. A visual inspection of this product before installation for any damage during shipping is recommended.

GENERAL INFORMATION

WARNING

BEFORE BEGINNING INSTALLATION OF THIS MURPHY PRODUCT

- ✓ Disconnect all electrical power to the machine.
- ✓ Make sure the machine cannot operate during installation.
- ✓ Follow all safety warnings of the machine manufacturer.
- ✓ Read and follow all installation instructions.

Description

The TTDJ is a solid-state fault annunciator and shutdown control system, with hour meter, designed to protect engines, compressors and their associated equipment. Four TTDJ modules are available:

- TTDJ-DC** : Powered by 12 or 24 VDC systems without tachometer and overspeed sensing. Includes RS485 serial port.
- TTDJ-DC-T** : Powered by 12 or 24 VDC systems with internal tachometer and overspeed sensing. Includes RS485 serial port.
- TTDJ-IGN** : Powered by negative ground CD ignition systems without tachometer and overspeed sensing. Without RS485 port.
- TTDJ-IGN-T** : Powered by negative ground CD ignition systems with internal tachometer/overspeed sensing. Without RS485 port.

All TTDJ models will accept 32 sensor inputs from normally open and/or normally closed sensors. Each of the first 16 inputs can be configured for Shutdown or Alarm Before Shutdown*, and can be locked out by one of the Two Start-Run timers (B1:0-5 min.; B2:0-9:59 min.), or configured as Class C. The annunciator provides for both closing of a fuel valve, and grounding of an ignition after a time delay. The TTDJ has built-in Elapsed Time Meter. Run Hours and Tachometer Settings are stored in non-volatile memory, as well as the last 4 shutdowns and one alarm (alarm only stored if active at the time of shutdown). The TTDJ liquid crystal display annunciates any fault from the sensor inputs, displays engine speed and elapsed time.

Other features for all TTDJ models are: built-in Test Mode to test the sensor circuits without shutting down, on-board backup battery to retain the fault display after shutdown (IGN models only), and a history of the last 4 shutdowns with their associated Run Hours, also stored in non-volatile memory.

TTDJ-DC and TTDJ-DC-T models feature an RS485 serial communications port (MODBUS RTU slave) to interface with micro-controllers, PC'S, PLC's and controllers.

Module/ Head

The module is the brain of the control system. It contains the microcomputer, the Liquid Crystal Display (LCD), the membrane keys for configuring the sensors inputs, the Sensor Inputs Terminal Blocks and the Power Inputs and Control Output Terminal Block. The TTDJ-DC module also includes an RS485 serial communications port (MODBUS RTU slave).

*Alarm Before Shutdown is a function that causes annunciation and the alarm output, but will not cause a shutdown.



US Patent 6,144,116
(model TTDJ-IGN-T only)

CSA Certified for Use in Class I, Div. 2,
Groups C and D Hazardous Areas.

Liquid Crystal Display

The Liquid Crystal Display sequentially provides shutdown/alarm condition, run hours, rpm, and timer information. A shutdown or alarm condition is indicated by the appropriate sensor number in the first two leftmost digits. Hours display uses all the digits. RPM display is shown in the rightmost digits with a Run Indicator in the first digit. The Timer display shows the timer number in the first digit and the time in the last three digits.

Timers

Active Timers are indicated by the timer number in the first digit of the display, and the remaining time in the last three digits. Timer 1= Class "B1", Timer 2= Class "B2", Timer 3= Test, Timer 4= Ignition Ground Delay.

Power and Control Inputs/Outputs

The TTDJ power and control inputs and outputs are connected to the Power Inputs terminal block on the back of the TTDJ.

In the TTDJ-IGN and TTDJ-IGN-T the FV+ output is a non-switched output that supplies stored energy from an internal capacitor. -FV and ALARM outputs are non reversible switched outputs (switched OFF for normal operation, switched ON for alarm and shutdown). When a shutdown fault is detected, the -FV and ALARM turn ON and after a time delay, the IGN input switches to ground. The alarm output does not operate for Manual Stop (code 52).

On the TTDJ-DC and TTDJ-DC-T the IGN, FV, and ALARM outputs are programmed to switch ON for normal operation.

Sensor Inputs and Terminals

Up to 32 dry contact sensor inputs or Murphy device transistor outputs can be connected to the back of the TTDJ via a terminal block (32 pair, screw type, each with a jumper). Sensor inputs 1 to 16 are configurable as Class "A", Class "B1", Class "B2" or Class "C" functions, Shutdown or Alarm Before Shutdown*. The Class "B" timers allow sensor inputs to be locked out at start-up. Sensor inputs configured for Alarm Only will cause the Alarm Output to turn on when tripped, and the sensor number will be annunciated while the unit continues to run. TTDJ sensor inputs 17-28 are dedicated as Class "A" Shutdown only. Sensor input 29 can be configured as a Class "A", or Class "ESD" input. Sensor input 32 is dedicated as Class "ESD". Sensor inputs 30 & 31 can have special functions or be Class "A". Any tripped sensor is detected within 1 second after faulted.

Emergency Shutdown

Sensor input number 32 is dedicated to Emergency Shutdown. The Emergency Shutdown sensor input overrides the Test timer. Additionally, sensor input 29 can be configured as a Class "A" or Class "ESD" input.

Remote Reset (optional, Setup 5 = 1, 3, 5 or 7)

When the Remote Reset feature is selected, point 30 with a closed contact resets the TTDJ in the same manner as when using the Reset key. The closed contacts to operate the Remote Reset feature should be kept closed only momentarily for approximately 1 second to cause a remote reset.

Remote Lockout (optional, Setup 5 = 2, 3, 6 or 7)

The Remote Lockout inhibits the Class B1 and Class B2 Lockout timers. These Lockouts are ignored when a closed switch is seen at Input 31. An open switch at Input 31 allows the Lockouts to function normally. When the Remote Lockout is active it resets Class "C", "B1" and "B2" Lockout timers. This is intended to be used with automatic starting systems. With a contact closure on terminals 31 with the unit not running, the display will alternate between either RPM (-T models) and the Class "B1" timer, or the display will flash (non-T models). The TTDJ should be put into remote lockout immediately before stopping the engine. The contact closure should be opened once the engine is running. At that time the "B1" and "B2" timers will be allowed to count down.

Reset Key

The Reset key resets All faults and initiates the Class "B" timers.

Overspeed (-T models only)

These models feature an internal tachometer with Overspeed Shutdown (50). This shutdown bypasses the Ignition Ground Delay. It is not locked out by the Test Timer.

Underspeed Annunciation (-T models only)

TTDJ-IGN-T models display (51) when an underspeed condition occurs. It is not locked out by the Test Timer.

Loss of Ignition Annunciation (non -T models)

The TTDJ-IGN models will display (51) when ignition input is lost. It is not locked out by the Test Timer.

Run/Stop Key (Manual Stop)

The Manual Run/Stop key is used for system shutdown from the panel. When pressed, the unit will shutdown the system without turning on the Alarm Output (on -DC models the Alarm Output is turned off on Manual Stop). Manual Stop (Shutdown 52) is not locked out by the Test Timer.

Low Backup Battery Voltage (-IGN models)

The TTDJ-IGN models have an internal backup battery. When the "Lowbatt" display appears (this message will alternate with other displays) the battery needs to be replaced, see page 3 for details.

Timer "O" Key

This key zeros the current displayed timer: Class "B1", "B2", Ignition Ground Timer, or Test Timer. If the TTDJ is in the Test mode, it exits Test.

Test Key

Initiates the Test Timer with 5 minutes. Test mode is indicated by the "3" in the first digit of the display. Faulted inputs are displayed as in normal operation, but the system is not shutdown and the Alarm Output is not turned on. Press "Reset" to reset the fault and press the Timer "O" to exit. The following shutdowns override Test: Emergency Shutdown (32), Overspeed (50), Manual Stop (52), Underspeed (51), Loss of Ignition (51) and Optional Additional ESD if chosen as ESD. If Class "C" functions are used, they will need to be bypassed to test other sensors. When exiting "Test" with Class "C" functions, press "Reset" and "Timer 0" simultaneously.

Shutdown History

The TTDJ models store the last 4 shutdown codes and any alarm present

at shutdown, as well as the elapsed time reading at which they occurred. For instance, if the unit is shutdown from sensor input 1, the display will show "01 SD1" to indicate the last shutdown. Shutdown #1 was sensor input #1. Press the "Up" key for "Shutdown 2", "3", "4", and for any present "Alarm". To view the elapsed time reading at which any of the shutdowns occurred, press "Push To Read Hours" key while viewing that shutdown.

Class "B" Lockout Timer

Allows the system to become fully operational without shutting down by start-up related conditions. Class "B1" and Class "B2" Sensor inputs are locked out until their corresponding timer expires. Class "B1" Timer is selectable from 0:00-5:00 minutes, and Class "B2" Timer from 0:00-9:59 minutes.

Class "C" Functions

There is a practical limit of sensor inputs defined as Class "C" Shutdown and/or Class "C" alarm of 8 points. The Class "C" function operation is that the sensor will be initially faulted on Start-up. If the sensor never clears there will not be any annunciation and alarm or shutdown. If the sensor clears for a full 2 seconds, then it is armed to alarm or shutdown. Pressing the Reset key will allow a Class "C" alarm function to go back to the Start-up state where it can remain faulted without annunciation and alarm. An example of a Class "C" function is Low Discharge pressure.

Ignition Ground Delay

This delay is selectable from 0-20 seconds. To select the delay use SETUP.4, see User Set Up Menus and To Enter User Set Up on page 5.

Hourmeter

The TTDJ internal hourmeter keeps track of Run Hours. To display Run Hours for 5 seconds, press the Push to Read key. Run Hours are stored in non-volatile memory, maintaining hours in the absence of power.

RS485 Serial Port (TTDJ-DC / TTDJ-DC-T)

The RS485 serial port (MODBUS RTU slave) on the back of the module is provided for communicating with micro-controllers, PC's, PLC's and SCADA systems (see RS485 Typical Connections, below). It is recommended that a termination resistor** (customer supplied) be used on the first and last device connected in a daisy-chain configuration.

The communication parameters are 9600 baud, no parity, 8 bits with 1 stop bit (9600,N,8,1), half-duplex. The shield terminal on the TTDJ terminal block should only be used if the drain wire on the shielded cable is not connected to ground anywhere else. Each device must have a unique RTU node number. A retry delay of 0.3 second may be helpful (set up for 3 retries).

Modbus Integer Holding Registers

- 40001= RPM
 - 40002= ETM (elapsed Time Meter 0-65535 Hrs.)
 - 40003= Class B1 (in seconds)
 - 40004= Shutdown Numbers (0=OK) (1-32, 50-52 =SD shutdown)
 - 40005= Output Status (Bit 0= IGN, Bit 1= FV, Bit 2= ALR)
 - 40006= Inputs 1-16 (Bit 0 = TB1..., Bit 15= TB16) (True 1= Inactive)
 - 40007= Inputs 17-32 (Bit 0= TB17..., Bit 15= TB32) (True 1= Inactive)
- If 40006 and 40007 both contain "FF" there are no active shutdowns.*

RS485 typical connections

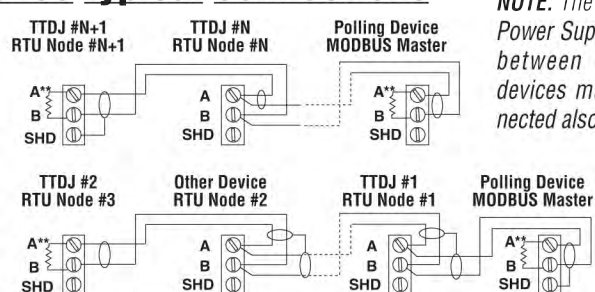

NOTE: The common or Power Supply grounds between connected devices must be connected also.

**Terminating resistor is 120 ohms. Install Terminating resistor at the master and the last slave. Use only Belden 9841 or 3105A cable or cabling with a characteristic impedance of 120 ohms.

SPECIFICATIONS

Power Input (Operating Voltages):

TTDJ-DC; TTDJ-DC-T Models: 10- 32VDC, 500 mW max.
TTDJ-IGN; TTDJ-IGN-T Models: 90-350 VDC negative ground
 CD ignition; approx. 650µA @ 100VDC.

Sensor Inputs: 32 N.O. or N.C. passive switches.

Inputs 1-16: Configurable as Class "A", "B1", "B2", or "C" Shutdown or Alarm Before Shutdown*.

Inputs 17-28: Dedicated Class "A" shutdowns.

Inputs 29: Configurable as Class "A" or Class "ESD".

Input 30: Selectable Remote Reset or Class "A".

Input 31: Remote Lockout or Class "A"; inhibits the Class "B1 & B2" Lockout Timers.

Input 32: Class "ESD" Overrides Test Timer, typically used for emergency shutdown.

Outputs: 0.5 A @ 350 VDC.

Outputs Selection: Ground ignition immediately or trip fuel valve and ground ignition after time delay.

Communications: RS485 Serial Port, Modbus RTU slave (TTDJ-DC models).

Operating Temperature: -40 to 185°F (-40 to 85°C).

Storage Temperature: -40 to 185°F (-40 to 85°C).

Sensor Scan Rate: Within 1 second.

B1 Start/Run Timer: Adjustable, 0 - 5 minutes.

B2 Start/Run Timer: Adjustable, 0 - 9:59 minutes.

Pulses per Revolution Range for Tach. Calibration:
 32-360 (TTDJ-DC-T); 1 - 16 (TTDJ-IGN-T).

Overspeed Set point: 0 - 9999 rpm.

Underspeed Set point: 0 - 5000 rpm.

Magnetic Pickup: 5 - 120 Vrms, 0-10 kHz.

On-Board Backup Power 00005125 (-IGN Versions only):

6 VDC, 1300 mAh, Duracell® DL223A or Sanyo® CR-P2 Lithium battery.

Tachometer Accuracy: ±0.5% of the display reading or ±1 RPM whichever is greater.

Hourmeter Range: 0 to 65535 hrs.

Hourmeter Accuracy: ±15 minutes per year.

*Alarm Before Shutdown is a function that causes annunciation and the alarm output, but will not cause a shutdown.

TTDJ MOUNTING DIMENSIONS (All Models)



WARNING: PERFORM THE MOUNTING OPERATION WITH POWER SOURCE OFF. THE TTDJ SERIES MODULE WAS DESIGNED TO BE MOUNTED WITHIN A WEATHERPROOF ENCLOSURE. IT IS INTENDED FOR MOUNTING IN A FLAT PANEL. A SQUARE MOUNTING HOLE OF 5-1/2 IN. (140 MM) AND FOUR MOUNTING SCREW HOLES ARE NEEDED. INSERT THE MODULE FROM THE FRONT SIDE OF THE PANEL AND SECURE THE FOUR MOUNTING SCREWS AND NUTS THROUGH THE BEZEL.

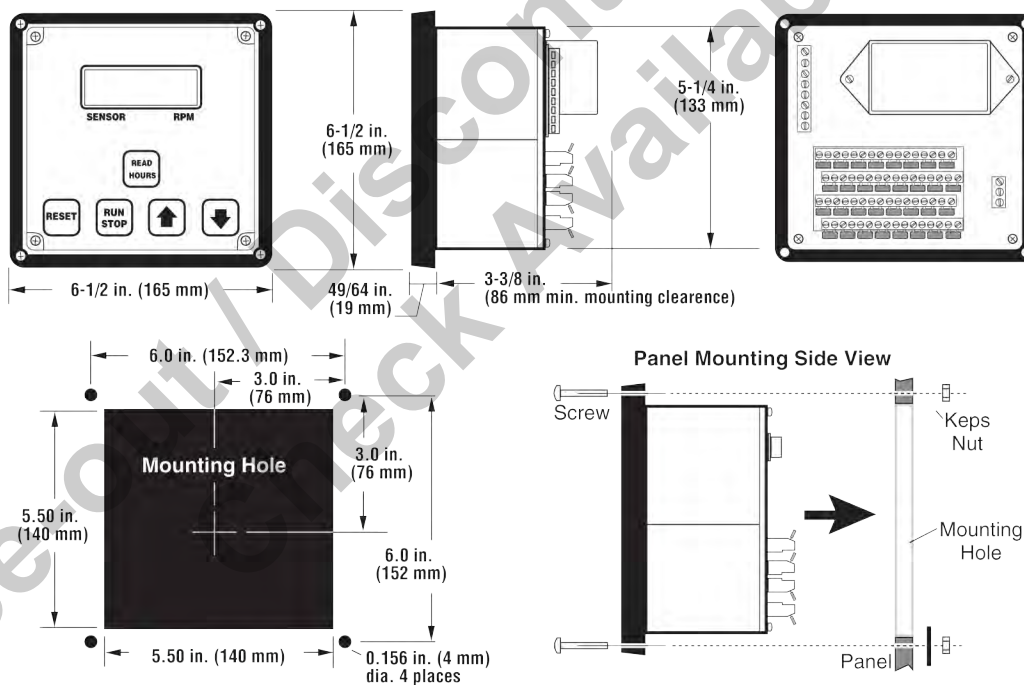

REPLACING THE BATTERY (-IGN Models only)



WARNING: THE BACKUP POWER BATTERY IS LOCATED WITHIN THE TTDJ MODULE. THEREFORE, EXTREME CAUTION MUST BE EXERCISED WHEN REPLACING IT. FOR CLASS 1, DIVISION 2, HAZARDOUS AREAS INSTALLATIONS, FIRST, SHUTDOWN THE SYSTEM AND MAKE SURE THAT THE HAZARDOUS AREA IS KNOWN TO BE NON-HAZARDOUS BEFORE OPENING THE POWER SUPPLY COVER.

The TTDJ-IGN models include a Backup Power Battery located within the TTDJ module. To gain access to and to replace the battery do the following:

1. Make sure the area is made Non-Hazardous and shut down the System (remove power).
2. Using extreme caution remove the Power Supply Cover Screws (located on the back of the TTDJ module).
3. Gently pull the Power Supply Cover away from the back of the TTDJ to have access to the old Backup Battery.
4. Locate the old Backup Battery.
5. Using extreme caution, not to damage any component, replace the battery with a 6 VDC, 1300 mAh, Duracell® DL223A or Sanyo® CR-P2 Lithium battery, available from Murphy (p/n **00005125**).
6. Carefully proceed to replace the Power Supply Cover.
7. You are now ready to power up your system and resume operations.

TYPICAL WIRING DIAGRAMS (All Models)



WARNING: FOR HAZARDOUS APPLICATION REQUIREMENTS, THE TTDJ COMPLETE SYSTEM MUST BE INSTALLED IN ACCORDANCE WITH THE NATIONAL ELECTRICAL CODE (NEC) CLASS I, DIVISION 2, GROUPS C & D (ARTICLE 504) SPECIFICATIONS AND PER MURPHY DRAWING 50-08-0039. SENSOR INPUT WIRES MUST BE SEPARATED A MINIMUM OF 2 IN. (51 MM) FROM OTHER WIRES.

TTDJ-DC AND TTDJ-DC-T TYPICAL WIRING

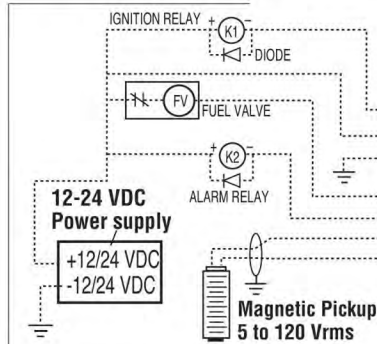

User wiring installed per NEC for Class I, Div. 2, Grps. C & D hazardous locations.

NOTES:

1. Sensors are normally open or normally closed mechanically actuated passive switches, or Murphy, certified, non-incendive or intrinsically safe products.
2. Non-incendive field circuits—VOC= 10.5 VDC, ISC= 320 μ A.
3. SD, FV and Alarm outputs are rated 0.5 A continuous 350 VDC.
4. Power supply, power input 10-32 VDC, 16 W max.
5. K1 and K2 must be hermetically sealed relays, CSA or UL approved for use in Class I, Div. 2, Grps C & D hazardous locations.
6. Fuel Valve in this diagram could be another relay like K1 and K2.

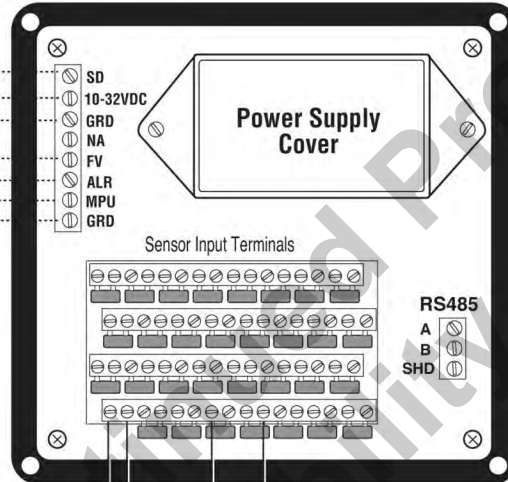

- WARNING -
Explosion hazard.
DO NOT Connect or disconnect RS485 leads unless the area is known to be non hazardous.

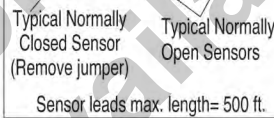

Non-incendive field wiring connections to passive switches. Route leads separate from other wiring, refer to Notes 1 and 2.

TTDJ-IGN AND TTDJ-IGN-T TYPICAL WIRING

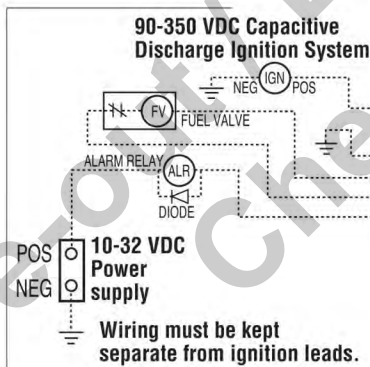

User wiring installed per NEC for Class I, Div. 2, Grps. C & D hazardous locations.

NOTES:

1. Sensors are normally open or normally closed mechanically actuated passive switches or Murphy certified, non-incendive or intrinsically safe products.
2. Non-incendive field circuits—VOC= 10.5 VDC, ISC= 320 μ A.
3. IGN, FV and Alarm outputs are rated 0.5 A continuous 350 VDC.
4. Power input 90-350 VDC, CD ignition.
5. ALR relay must be hermetically sealed relay, CSA or UL approved for use in Class I, Div. 2, Grps C & D hazardous locations.

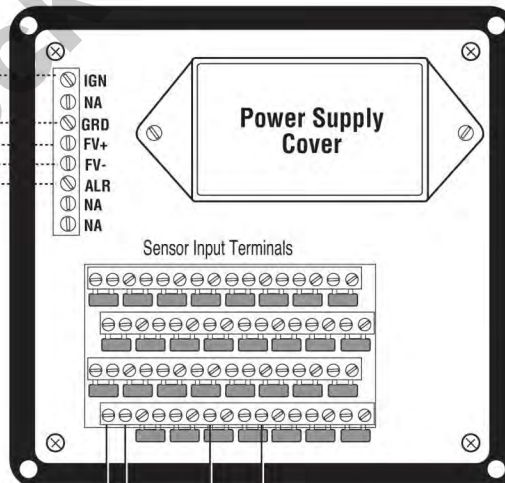

Alternate hook-up for using latching 48 VDC coil solenoid for alarm air horn.

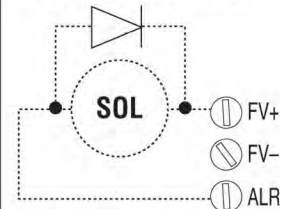

NOTE: FV- terminal cannot be used with this hook-up for a CD fuel valve.

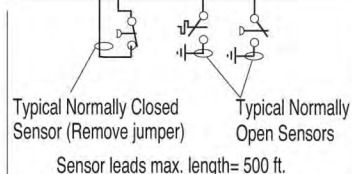

Non-incendive field wiring connections to passive switches. Route leads separate from other wiring. Refer to Notes (1,2).

TTDJ SENSOR SETUP MAP

TYPE SETUP

TYPE SETUP

SETUP.3

STOP

CODE100

CODEXX 0-99

- Type 0 = Class A Shutdown
- Type 1 = Class B1 Shutdown
- Type 2 = Class B2 Shutdown
- Type 3 = Class C Shutdown
- Type 4 = Class A Alarm Before Shutdown
- Type 5 = Class B1 Alarm Before Shutdown
- Type 6 = Class B2 Alarm Before Shutdown
- Type 7 = Class C Alarm Before Shutdown

Sensor 1-16 Setup Detail

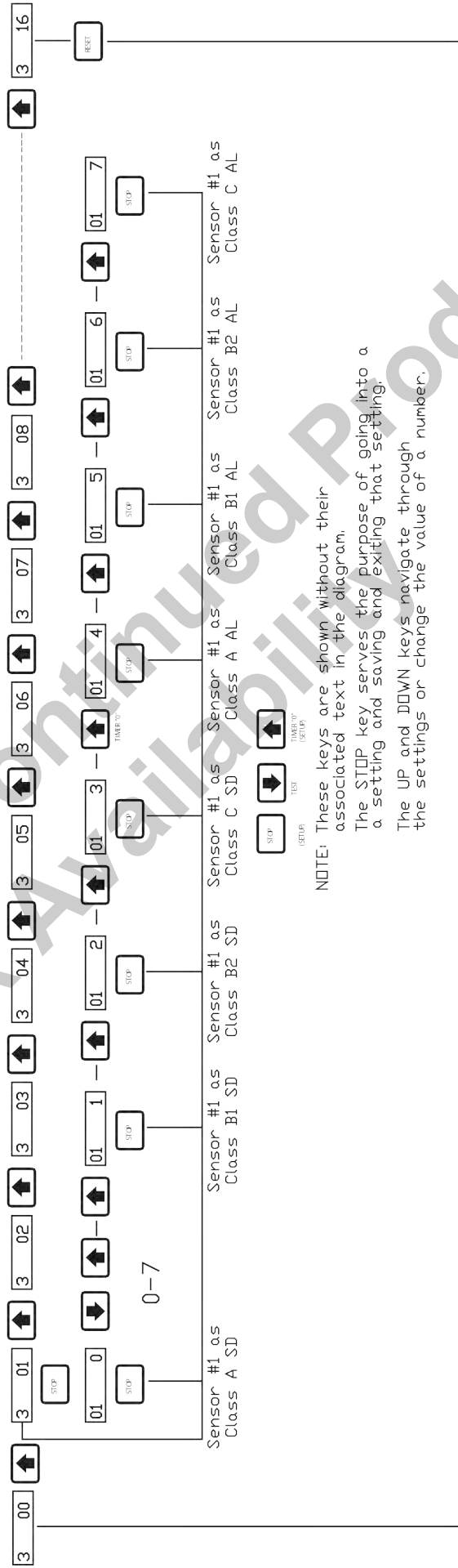

TTDJ SETUP MAP

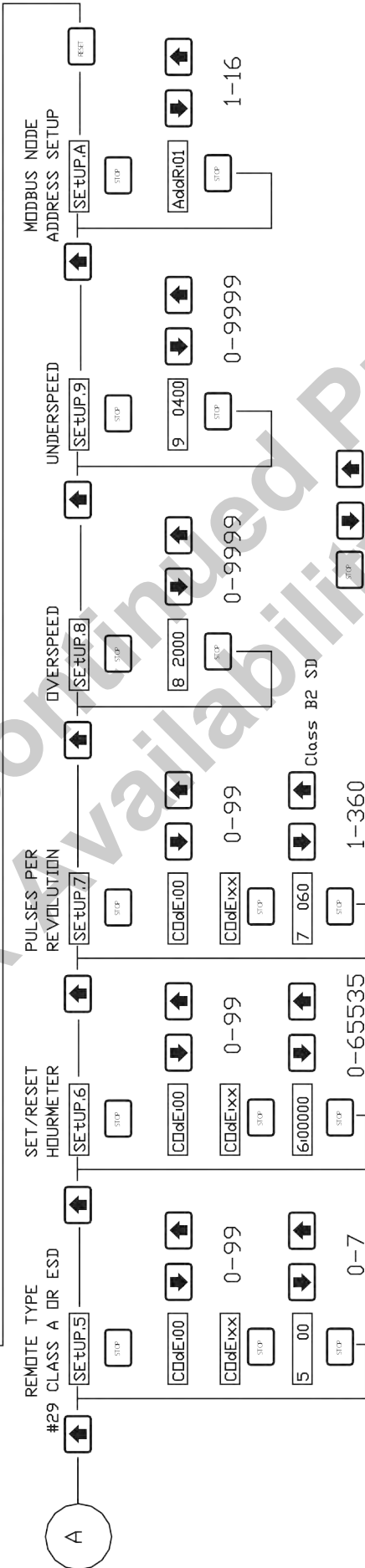
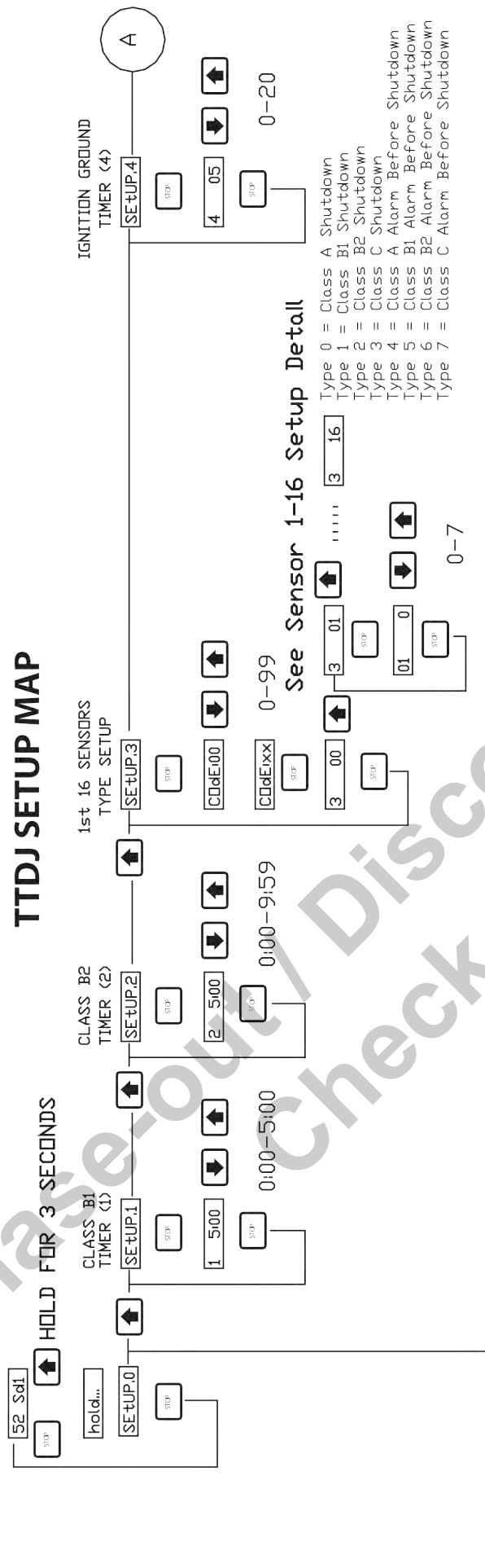

0 = No Remote Lockout or Reset, #29 is Class A
 1 = Remote Reset, No Remote Lockout, #29 is Class A
 2 = Remote Lockout, No Remote Reset, #29 is Class A
 3 = Remote Reset and Lockout, #29 is Class A
 4 = No remote Reset or Lockout, #29 is Class ESD
 5 = Remote Reset, No Remote Lockout, #29 is Class ESD
 6 = Remote Lockout, No Remote Reset, #29 is Class ESD
 7 = Remote Reset and Lockout, #29 is Class ESD

NOTE: These keys are shown without their associated text in the diagram. The STOP key serves the purpose of going into a setting and saving and exiting that setting. The UP and DOWN keys navigate through the settings or change the value of a number.

User Set Up Menus

The following are the User Setup Menus for All TTDJ models:

- SETUP.1 SETUP.1 = Class B1 Timer (0 – 5:00)
- SETUP.2 SETUP.2 = Class B2 Timer (0 – 9:59)
- *SETUP.3 SETUP.3 = Sensor 1-16 Type Setup
- SETUP.4 SETUP.4 = Ignition Ground Delay (0 – 20 sec.)
- *SETUP.5 SETUP.5 = Remote Setup
 0= No Remote Lockout or Reset, #29 is Class “A”
 1= Remote Reset, No Remote Lockout, #29 is Class “A”
 2= Remote Lockout, No Remote Reset #29 is Class “A”
 3= Remote Reset, and Lockout, #29 is Class “A”
 4= No Remote Reset or Lockout, #29 is Class “ESD”
 5= Remote Reset, No Remote Lockout, #29 is Class “ESD”
 6= Remote Lockout, No Remote Reset #29 is Class “ESD”
 7= Remote Reset and Lockout, #29 is Class “ESD”

*SETUP.6 SETUP.6 = Hours Setup

The User Setup Menu shown below are also available for -T models:

- *SETUP.7 SETUP.7 = Pulses per revolution
- SETUP.8 SETUP.8 = Overspeed
- SETUP.9 SETUP.9 = Underspeed

The User Setup Menu shown below is for ALL -DC models:

SETUP.A SETUP.A = Modbus RTU node number 1-16 (-DC models)

*These Set Up Menus are code protected (for all models).

To Enter User Set Up Menus

(Must be in Manual Stop #52)

To enter the User Setup Menus the TTDJ unit Must be in the Manual Stop (#52) condition. If a shutdown is present other than Manual Stop, press the “Reset” key, then immediately Press and Hold Both the Run/Stop and Up (Timer 0) keys. Now follow these steps:

1. Press and hold both the Run/Stop and Up (Timer 0) keys until the LCD reads hold... (HOLD).
2. Continue to hold both keys for 3 more seconds approximately. The display reads SETUP.0 (SETUP.0), you are now in the User Setup Menu.
3. Use the Up key (Timer 0) and Down (Test) keys to select the desired Setup Menu.
4. Press the Run/Stop key to enter the desired Setup Menu.

NOTE: Some settings are password protected.

5. Use the Up and Down keys to preset the desired parameter. Press Reset to zero the value.
6. When the desired value is entered, press Run/Stop.
7. Repeat Steps 3-6 until all parameters are preset.
8. To exit User Setup, select SETUP.0 and press Run/Stop.

Code Protection

For Setup Menus that are code protected, the LCD will read “CODE.00” prompting the user to enter a code before allowing setup. Use the Up and Down keys to enter the code. If the code is entered incorrectly, the LCD will read “Error”. After 3 incorrect entries, the Code Setup is exited. Once the correct Code is entered, the Setup Menu is accessed.

To Calibrate the Tachometer (TTDJ-DC-T and TTDJ-IGN-T models)

The TTDJ measures RPM based on the number of pulses per engine revolution. To calibrate the tachometer first enter the User Set Up Menu, see steps 1-3 from “To Enter User Set Up Menus” above.

Select SETUP.7. Enter the code, then enter your number of pulses per engine revolution (refer to Pulses/Revolution, above right).

Pulses/Revolution

TTDJ-IGN-T (Ignition Model)

For this model the number of pulses per revolution is determined by the number of cylinders and cycles of the engine, according to the following table:

Cylinders	Cycles	Pulses	Cylinders	Cycles	Pulses
1	2	1	6	2	6
2	2	2	6	4	3
2	4	1	8	2	8
3	2	3	8	4	4
4	2	4	10	4	5
4	4	2	12	4	6
5	2	5	16	4	8

NOTE: Divide the number of cylinders by 2 for split capacitor ignitions. Multiply the number of cylinders by 2 for throw away spark ignitions.

TTDJ-DC-T (DC Model)

For TTDJ-DC-T models the pulses per revolution can come from a magnetic pickup. The number of pulses per revolution is simply the number of teeth on the flywheel gear (32 to 360).

Sensor Input Set Up

Sensor inputs 1-16 are configurable. The following types are available:

- Type 0 = Class A, Shutdown
- Type 1 = Class B1, Shutdown
- Type 2 = Class B2, Shutdown
- Type 3 = Class C, Shutdown
- Type 4 = Class A, Alarm Before Shutdown†
- Type 5 = Class B1, Alarm Before Shutdown†
- Type 6 = Class B2, Alarm Before Shutdown†
- Type 7 = Class C, Alarm Before Shutdown†

To configure a Sensor Input:

1. Enter the SETUP.3 menu (enter the code). The Display will read: 3 00 (3 00).
2. Use the Up and Down keys to select the input to be configured. For example if you select Input #1 the display reads: 3 01 (3 01).
3. Press the Run/Stop key. Assuming you selected Input #1, and that input is currently configured as a Class A, Shutdown, the display will read 01 0 (01 0).
4. Use the Up and Down keys to select the desired Sensor Input Type.
5. Press the Run/Stop key, the display reads: 3 01 (3 01).
6. Repeat Steps 2-5 as necessary.
7. To Exit press Reset, the display shows: 3 00 (3 00). Then press the Run/Stop key.

Elapsed Time Set / Reset

Enter the Elapsed Time Set Up, SETUP.6. First make sure the jumper for Input #30 is installed. To Set the time do the following:

1. Enter the SETUP.6 menu (enter the code). The display will read the elapsed time in hours, after the 6 (for example: 6.00001 (6.00001) if the elapsed time is 1 hour).
2. Set the desired time using the Up/Down keys. Press Reset to zero the time.
3. When the desired time is entered, press the Run/Stop key.
4. To exit User Setup, press Reset, the display will show: SETUP.0 (SETUP 0) and press the Run/Stop key.

NOTE: Decimal fractional of the elapsed time is lost when the Elapsed Time Setup is entered, and it can only be set to the nearest hours.

† Alarm Before Shutdown is a function that causes annunciation and the alarm output, but will not cause a shutdown.

SEQUENCE OF OPERATIONS

System Start Up

Press the **RESET** key to clear any faulted sensor input and unground/enable ignition for engine operation. Apply starting power to the engine.

Engine Speed (-T models only)

The first thing displayed on versions with Tachometer is the engine speed. While there is time remaining in either of the Class "B" timers, the display will alternate between engine speed and the Class "B" timers (4 seconds each). Once the Class "B1" timer expires, while there is time remaining in the Class "B2" timer, the display will alternate between the engine speed and the Class "B2" timer (4 seconds each). Once both Class "B" timers expire, the engine speed is displayed continuously.

Class "B1" Timer

While there is time remaining in the Class "B1" timer, the display will alternate between engine speed and the Class "B1" time remaining for example: "1 0:30" (4 seconds each). All sensor inputs configured as Class "B1" are locked out at this point. For non -T models the "B1" display will be steady. To zero this timer, press **TIMER "0"**.

Class "B2" Timer

Once the Class "B1" timer expires while there is time remaining in the Class "B2" timer, the display will alternate between engine speed and the Class "B2" time remaining for example: "2 0:30" (4 seconds each). All sensor inputs configured as Class "B2" are locked out at this point. For non -T models the "B2" display will be steady. To zero this timer press the **TIMER "0"** key, after the Class "B2" timer has expired.

Elapsed Time

To display the run hours, press the **"Display Hours"** key. The current Run hours will be displayed for 5 seconds. **NOTE:** On all non tachometer models (non -T) the **RUN HOURS** are displayed after the Class "B" Timers expire, instead of **ENGINE SPEED**. The decimal point flashes to indicate the unit is running.

Alarm Only Condition

If any one of the sensor inputs configured as an **ALARM-ONLY** is faulted, the Alarm Output will turn ON, and the sensor number will be displayed in the first two digits. Press the **RESET** key after the sensor input has cleared, to clear the display and to turn OFF the Alarm output.

Overspeed (-T models only)

If the engine speed exceeds the Overspeed Set point the engine will shutdown, bypassing the Ignition Ground Delay. The TTDJ-T models will display "50". Overspeed overrides the Test mode.

Underspeed (-T models only)

If after the Class "B1" Timer expires the engine speed falls below the Underspeed Setpoint, the engine will shutdown. The TTDJ will annunciate/display "51". Underspeed overrides the Test mode.

Manual Stop

To manually shutdown the engine, press the **STOP/RUN** key. The TTDJ will shutdown the system and the display will indicate "52". Manual Stop overrides the Test mode.

Ignition Ground Delay

Upon reaching a shutdown condition, the unit will trip the fuel valve, and, after the delay expires, ground the ignition. This delay is bypassed on **Overspeed (50)**, **Emergency Shutdown (32)**, and sensor input #29 if configured as Class "ESD".

Loss of Ignition

TTDJ-IGN models annunciate/display "51" when ignition input is lost.

The energy stored in the FV+ circuit will trip the fuel valve.

Resetting Shutdown Fault

After the shutdown condition is cleared on the equipment, press **RESET** key.

Test Timer









The Test Timer is used to verify that sensors are wired properly and working correctly. To perform a sensor test while running do the following:

1. Press the **TEST** key and verify that the Test Timer is shown with 5 minutes: (3 5.00).
2. Trip the first sensor to be tested and verify that the sensor number and class type appear on the display (see displays below). The display will alternate between the Sensor Number and the Test timer.
3. Clear the sensor then press the **RESET** key. Verify that the sensor number is cleared from the display.
4. Repeat Steps 2 and 3 for each sensor.
5. To exit, press the **TIMER "0"** key or allow the Test Timer to expire.

NOTE: Any of the following conditions will override the Test Timer: **Emergency Shutdown (32)**, **Overspeed Shutdown (50)**, **Underspeed Shutdown -T models (51)**, **Loss of Ignition (51) non-T models**, **Manual Stop (52)**, and **sensor input #29, if configured as a Class "ESD"**.

Test Mode Display

In Test, when a sensor is tripped, the sensor number and the Class type are displayed, for example if sensor #1 (01) a Class "B1" shutdown is tripped in the Test the LCD reads "01 t1". The following are the Test Mode Displays:

	(t0): Class "A" Shutdown
	(t1): Class "B1" Shutdown
	(t2): Class "B2" Shutdown
	(t3): Class "C" Shutdown
	(t4): Class "A" Alarm
	(t5): Class "B1" Alarm
	(t6): Class "B2" Alarm
	(t7): Class "C" Alarm

Warranty

A limited warranty on materials and workmanship is given with this Murphy product. A copy of the warranty may be viewed or printed by going to www.fwmurphy.com/support/warranty.htm

INNOVATION CONTROLS CORPORATE HEADQUARTERS
5311 S 122ND EAST AVENUE
TULSA, OK 74146

INNOVATION CONTROLS – SAN ANTONIO OFFICE
5757 FARINON DRIVE
SAN ANTONIO, TX 78249

INNOVATION CONTROLS – HOUSTON OFFICE
105 RANDON DYER RD
ROSENBERG, TX 77471

INNOVATION CONTROLS LTD. – UNITED KINGDOM
CHURCH ROAD LAVERSTOCK
SALISBURY SP1 1QZ UK

MURPHY ECONTROLS TECHNOLOGIES (HANGZHOU) CO, LTD.
77 23RD STREET
HANGZHOU ECONOMIC & TECHNOLOGICAL DEVELOPMENT AREA
HANGZHOU, ZHEJIANG 310018 CHINA

DOMESTIC SALES & SUPPORT

ECONTROLS PRODUCTS
PHONE: 210 495 9772
FAX: 210 495 9791
EMAIL: INFO@ECONTROLS.COM
WWW.ECONTROLS.COM

MURPHY PRODUCTS
PHONE: 918 317 4100
FAX: 918 317 4266
EMAIL: SALES@FWMURPHY.COM
WWW.FWMURPHY.COM

MURPHY CONTROL SYSTEMS & SERVICES
PHONE: 281 633 4500
FAX: 281 633 4588
EMAIL: CSS-SOLUTIONS@FWMURPHY.COM

MURPHY INDUSTRIAL PANEL DIVISION
PHONE: 918 317 4100
FAX: 918 317 4124
EMAIL: IPDSALES@FWMURPHY.COM

INTERNATIONAL SALES & SUPPORT

UNITED KINGDOM
PHONE: +44 1722 410055
FAX: +44 1722 410088
EMAIL: SALES@INNOVATIONCONTROLS.COM
WWW.FWMURPHY.COM

CHINA
PHONE: +86 21 6237 5885
FAX: +86 21 6237 5887
EMAIL: APSALES@FWMURPHY.COM

LATIN AMERICA & CARIBBEAN
PHONE: 918 317 2500
EMAIL: LASALES@FWMURPHY.COM

SOUTH KOREA
PHONE: +82 70 7951 4100
EMAIL: SKOREASALES@FWMURPHY.COM

INDIA
PHONE: +91 91581 37633
EMAIL: INDIASALES@FWMURPHY.COM

ISO 9001
REGISTERED



USA (TULSA) - ISO 9001:2008 FM 28221
USA (ROSENBERG) - ISO 9001:2008 FM 28221
UK - ISO 9001:2008 FM 20442
CHINA - ISO 9001:2008 FM 523851
Registered Facilities

Printed in the USA