

OPLC DPCO

Irrigation Pump Pressure Control

ys6345
revision A, 4th May 2004
catalogue section 05



- **Automatic control of diesel pump demand pressure**
- **Specifically designed for engines driving multiple irrigators**
- **Reduces capital and running costs**

Description

The OPLC DPCO (shown above right) is a variant of the OPL series 4.5 inch/114mm pressure Switchgag®. The gauge face includes adjustable high and low pressure limit contacts: the visible contacts have a self-wiping action for positive electrical switching. The DPCO model includes a dual-pole front facia switch that allows manual selection of START (idle) or RUN (active) throttle control modes.

The OPLC DPCO uses a cast aluminium, weatherproof case, with a hinged front for inspection and wiring connection. Pressure hose connection is via a 1/4" NPT fitting in the base.

Application

The OPLC DPCO is typically used with a Murphy AT-03069 throttle controller (shown above left) to maintain pressure in an irrigation pump system. The AT-03069 has a heavy duty throttle controller with high torque, solid state switching and an electronic clutch, making it ideal for many automatic and semi-automatic engine systems: for full details see document AT-04052B.

The AT-03069 receives high or low pressure signals from the OPLC-DPCO (see overleaf for typical electrical connection), and throttles the engine in response. The combined system has been designed to maintain near constant pressure, even when the engine is driving multiple irrigation systems.

Murphy also recommend the connection of a Murphy PD8183 pulsation dampener in the pressure line to eliminates pointer flutter.

Product specification

Case:	
material	die-cast aluminium
paint finish	polyurethane, red
sealing	weatherproof, NEMA 3R
process connection	1/4" NPT
Movement:	
dial	4.5 in. (114mm)
scales	white text on black background 0 - 20 Bar 0 - 200 PSI / 14 bar 0 - 300 PSI / 20 bar
sensing element	Bourdon C-tube, grade A phosphor bronze
accuracy	±1% for middle half of scale, ±2% for first and last quarters
geared movement	302 and 304 stainless steel
lens	optically clear polycarbonate
pointer	high visibility with a pointer calibration hub
contact/circuit rating	2A @ 30 VDC 1A @ 125 VAC
General:	
maximum ambient temperature	150°F / 66°C
approximate shipping weight	2.5 Kg
electromagnetic compatibility	to 89/336/EEC



FW Murphy
PO Box 470248
Tulsa, Oklahoma 74147, USA
tel: +1 918 317 4100
fax: +1 918 317 4266
email: sales@fwmurphy.com
web: www.fwmurphy.com

CONTROL SYSTEMS AND SERVICES DIVISION
PO Box 1819, Rosenberg, Texas 77471, USA
tel: +1 281 633 4500
fax: +1 281 633 4588
email: sales@fwmurphy.com

MURPHY DE MEXICO S.A. DE C.V.
Blvd. Antonio Rocha Cordero 300, Fracción del Aguaje
San Luis Potosí, S.L.P. México 78384
tel: +52 444 8206264
fax: +52 444 8206336
Villahermosa office tel: +52 993 3162117
email: ventasmex@murphymex.com.mx
web: www.murphymex.com.mx

FRANK W. MURPHY LTD.
Church Rd, Laverstock, Salisbury, SP1 1QZ, UK
tel: +44 1722 410055
fax: +44 1722 410088
email: sales@fwmurphy.co.uk
web: www.fwmurphy.co.uk

MURPHY SWITCH OF CALIFORNIA
41343 12th Street West,
Palmdale, CA 93551-1442, USA
tel: +1 661 272 4700
fax: +1 661 947 7570
email: sales@murphyswitch.com
web: www.murphyswitch.com

MACQUARRIE CORPORATION
1620 Hume Highway,
Campbellfield, Victoria 3061, Australia
tel: +61 3 9358 5555
fax: +61 3 9358 5558
email: murphy@macquarrie.com.au



USA - ISO9001:2000 FM 28221
UK - ISO9001:2000 FM 29422

In order to consistently bring you the highest quality, full featured products, we reserve the right to change our specifications and designs at any time.

Electrical connection

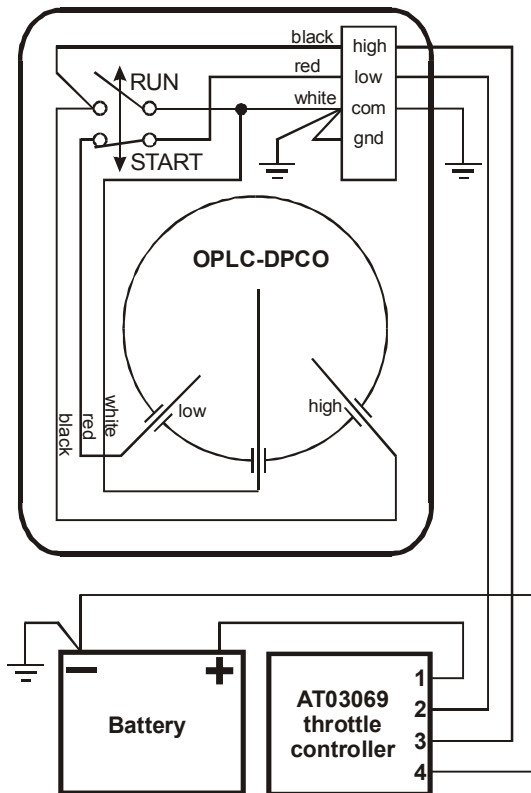

Dimensions

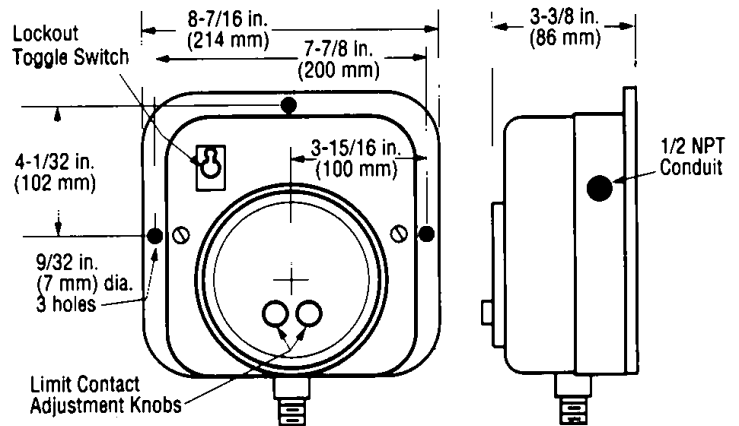

How to order

Model/stock ref.	Description
OPLCDPCO 20BAR	1/4" NPT, 0 – 20 Bar scale
OPLCDPCO 200PSI	1/4" NPT, 0 – 200 PSI/14 Bar scale
OPLCDPCO 300PSI	1/4" NPT, 0 – 300 PSI/20 Bar scale

Additional equipment:-

AT03069	Throttle controller, 12/24 VDC
PD8183 1/4 X 1/4	Pulsation dampener, 1/4" NPT fittings

Warranty

A two year limited warranty on materials and workmanship is given with these Murphy product. Full details are available on request and at www.fwmurphy.co.uk/warranty.

Further information

Document	Title
OPL-96001B	OPL series Switchgag® bulletin (full range)
OPL-9109N	OPL series Switchgag® installation
AT-04052B	AT-03069 throttle controller bulletin
AT-04060N	AT-03069 throttle controller installation
PD-95145B	PD8100 series pulsation dampener bulletin



FW Murphy
PO Box 470248
Tulsa, Oklahoma 74147, USA
tel: +1 918 317 4100
fax: +1 918 317 4266
email: sales@fwmurphy.com
web: www.fwmurphy.com

CONTROL SYSTEMS AND SERVICES DIVISION
PO Box 1819, Rosenberg, Texas 77471, USA
tel: +1 281 633 4500
fax: +1 281 633 4588
email: sales@fwmurphy.com

MURPHY DE MEXICO S.A. DE C.V.
Blvd. Antonio Rocha Cordero 300, Fracción del Aguaje
San Luis Potosí, S.L.P. México 78384
tel: +52 444 8206264
fax: +52 444 8206336
Villahermosa office tel: +52 993 3162117
email: ventasemex@murphymex.com.mx
web: www.murphymex.com.mx

FRANK W. MURPHY LTD.
Church Rd, Laverstock, Salisbury, SP1 1QZ, UK
tel: +44 1722 410055
fax: +44 1722 410088
email: sales@fwmurphy.co.uk
web: www.fwmurphy.co.uk

MURPHY SWITCH OF CALIFORNIA
41343 12th Street West,
Palmdale, CA 93551-1442, USA
tel: +1 661 272 4700
fax: +1 661 947 7570
email: sales@murphyswitch.com
web: www.murphyswitch.com

MACQUARRIE CORPORATION
1620 Hume Highway,
Campbellfield, Victoria 3061, Australia
tel: +61 3 9358 5555
fax: +61 3 9358 5558
email: murphy@macquarrie.com.au



USA - ISO9001:2000 FM 28221
UK - ISO9001:2000 FM 29422

In order to consistently bring you the highest quality, full featured products, we reserve the right to change our specifications and designs at any time.